

dimensions            50 x 50 x 27mm  
                               50 x 50 x 36mm

sensing range        diffuse reflection sensor   2 up to 50mm  
                               fiber optics                    1 up to 500mm

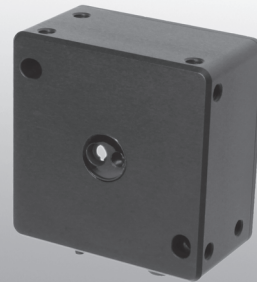

- ✓ integrated transmitting and receiving optics
- ✓ up to three colors can be stored (max. 31 in group mode)
- ✓ color, contrast and grayscale detection
- ✓ insensitive to ambient light
- ✓ 35kHz sampling frequency
- ✓ several TEACH options (via PC, PLC or button), status display is indicated using 2 yellow LEDs
- ✓ averaging can be switched on (from 1 to over 32000 values)
- ✓ color checking of primary light sources (LEDs, halogen lamps, displays)
- ✓ compact aluminum housing
- ✓ switchable brightness control
- ✓ various algorithms can be activated
- ✓ large selection of optical fibers

**max. 31 colors storeable white light LED, teach in**

Colour    
  I → |    
  DC    
  PNP    
  PC

**description**

The new **OF50** sensors from *ipf* fit seamlessly into the successful series of 'True Color' color sensors (see colors like a human does).

The devices can be easily installed as a result of their particularly compact housing. With its integrated optics, the **OF500170** is especially suitable for scanning large areas due to its large viewing angle, e.g. checking painted components or plastics in the interior of automobiles.

The **OF500180** has a fiber optic connection and, as such, scanning can also take place at positions where there is not much space available. With the help of the corresponding auxiliary lenses, the light beam can be focused in such a way that small objects can also be detected.

Via 2 digital outputs, it is possible to directly detect up to 31 different colors (up to 2 binary coded and up to 3 in group mode).

Through the integrated housing button (input IN0), the colors are taught quickly and easily. One special feature is the fact that the sensor can be taught two completely independent sets of parameters. Via the housing button, it is possible to select the desired parameter set.

Flexible signal recording enables the use of sensors in the ambient light independent alternating light mode (AC mode), as well as the ultra-fast direct light mode (DC mode).

In order to recognize 'primary light sources' (e.g. colored LEDs, lamps etc.), the super bright white light LED can be switched off. Via the PC software supplied with the sensor, it can be parameterized on almost any surface or any 'primary light source'.

Once the setting has taken place, the color sensor continues to work independently without the PC.

**application examples**

- ▶ monitoring the shade color on installed components
- ▶ color controlling painted components, imitation leather, plastics and textiles in car interiors
- ▶ removal of defective parts on the basis of color markers
- ▶ controlling the order of connector edging
- ▶ use as a trigger sensor in the printing industry (print mark detection)
- ▶ differentiating shades of panes of glass

article-no.  
sensing range  
version

**OF500170**  
2 ... 50mm  
dif. reflection sensor

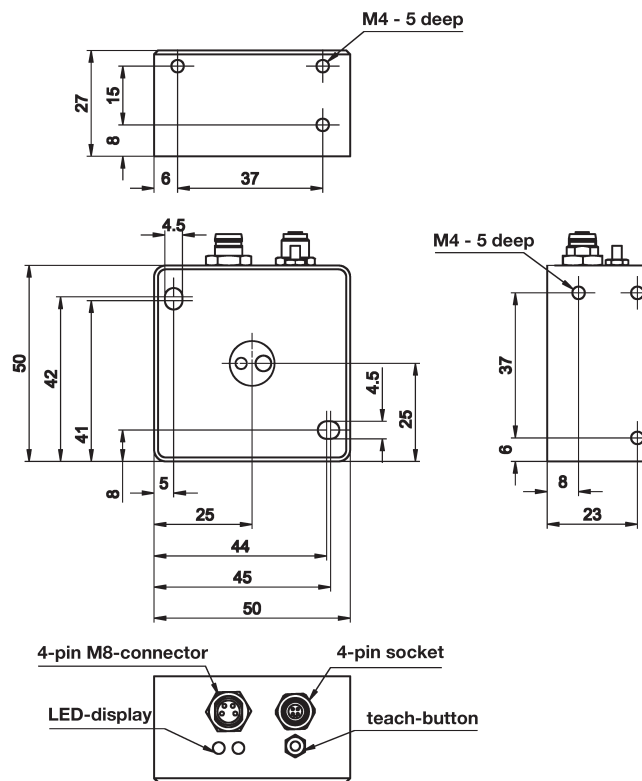

### TECHNICAL DATA

sensing range	typ. 2 ... 50mm
detection range	typ. 8mm with a 10mm gap * typ. 10mm with a 20mm gap * typ. 18mm with a 30mm gap * typ. 25mm with a 40mm gap * typ. 30mm with a 50mm gap *
output signal	2 x pnp / npn, light-on / dark-on mode
operating voltage	24V DC ±10%
current consumption (w/o load)	≤ 160mA
output current (max. load)	≤ 100mA per channel
transmitting element	white LED, pulsed / constant light
turn-off delay	0 ... 100msec
sampling frequency	35kHz
display (signal)	2 x yellow LED
setting	teach-in button, software
short-circuit protection	+
reverse polarity protection	+
dimensions	50x50x27mm
housing material	aluminium
operating temperature	-20 ... +55°C
storage temperature	-20 ... +85°C
system of protection (EN 60529)	IP67 (optics), IP65 (electronics)
interface	RS232
connection	PLC: M8-connector, 4-pin / PC: binder socket, 4-pin
connection accessories	2m PLC-cable e.g. <b>VK200375</b> / 2m PC-cable e.g. <b>VK207U44</b>

\* see page 4

article-no.

OF500180

sensing range

1 ... 500mm

version

fiber optics

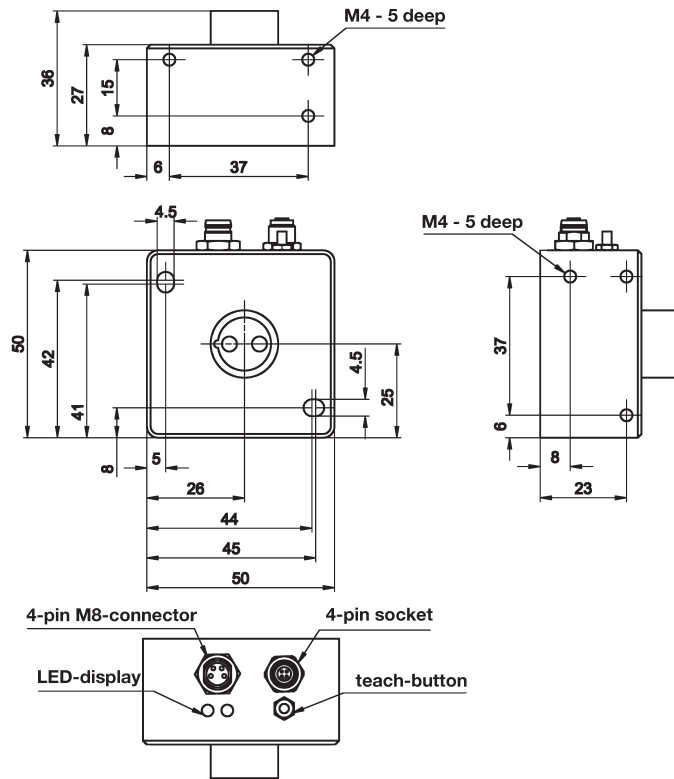

### TECHNICAL DATA

sensing range	typ. 1 ... 500mm
detection range	with reflective light fiber optics / transmitted light fiber optics: typ. 1 ... 25mm (depending on the reflective light, fiber optics, attachment optics that are used) with reflective light fiber optics / transmitted light fiber optics: typ. 10 ... 500mm (depending on the reflective light, fiber optics, attachment optics that are used)
light spot size	typ. 0.2 ... 20mm
output signal	2 x pnp / npn, light-on / dark-on mode
operating voltage	24V DC $\pm 10\%$
current consumption (w/o load)	$\leq 160\text{mA}$
output current (max. load)	$\leq 100\text{mA}$ per channel
transmitting element	white LED, pulsed / constant light
turn-off delay	0 ... 100msec
sampling frequency	35kHz
display (signal)	2 x yellow LED
setting	teach-in button, software
short-circuit protection	+
reverse polarity protection	+
dimensions	50x50x36mm
housing material	aluminium
operating temperature	-20 ... +55°C
storage temperature	-20 ... +85°C
system of protection (EN 60529)	IP54
interface	RS232
connection	PLC: M8-connector, 4-pin / PC: binder socket, 4-pin
connection accessories	2m PLC-cable e.g. <b>VK200375</b> / 2m PC-cable e.g. <b>VK207U44</b>
accessories	fiber optics / attachment lenses see data sheet <b>eOPSP1200</b>

### connection

#### PLC

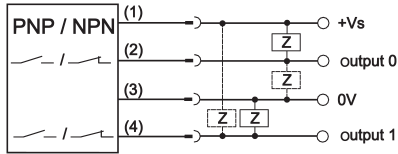

#### PC

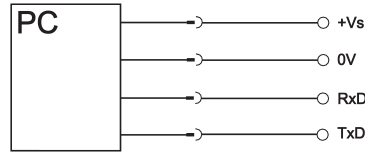

**wire colors:** bn = brown (1), wh = white (2), bu = blue (3),  
bk = black (4)

### capture range OF500170

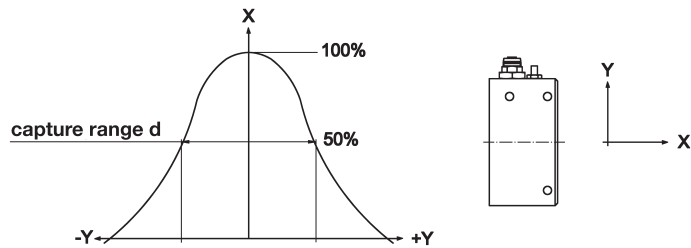

- d = typ. 8mm with a 10mm gap
- d = typ. 10mm with a 20mm gap
- d = typ. 18mm with a 30mm gap
- d = typ. 25mm with a 40mm gap
- d = typ. 30mm with a 50mm gap

This data sheet contains the standard versions only. Kindly request the availability of other output- and connection functions.

We will be pleased to supply the matching cable socket for your devices with connector. Please refer to the list in catalog chapter "accessories" under "cable sockets - **ipf-SENSORFLEX**" or search our Website for "VK".

**Warning:** Never use these devices in applications where the safety of a person depends on their functionality.

You also find this data sheet, as well as contact details under [www.ipf-electronic.com](http://www.ipf-electronic.com)

