

through-beam, diffuse reflection sensors 1500

dimensions **14.5 x 10 x 3.5mm**
14.5 x 13 x 3.5mm
14.5 x 4.5 x 10mm

through-beam sensors operating distance **up to 1000mm**
dif. reflection sensors sensing range **2 to 25mm**

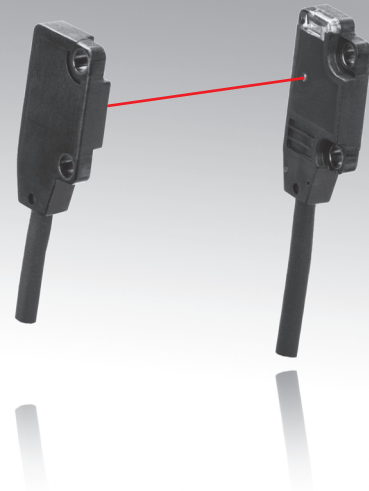
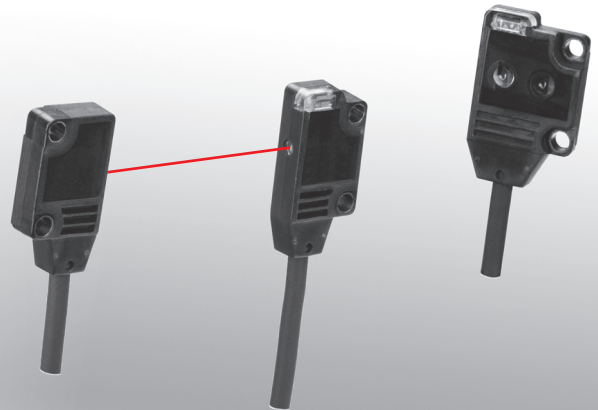

- ✓ high repeat accuracy
- ✓ extremely compact design
- ✓ robust plastic housing
- ✓ status display by red LED
- ✓ stand-by function by green LED
- ✓ integrated amplifier
- ✓ high sampling frequency
- ✓ connection with cable or M8-connector

visible red light
small light beam diameter



description

The devices of the design **Q3** and **Q4** are counted among the smallest optical sensors worldwide. Their extremely compact dimensions make them suitable for applications, which in the past had been reserved to fiber optics. The sensors have such a high repeat accuracy that they may be compared to laser sensors. The devices operate with a visible red light, which simplifies the adjustment.

The **OTQ30100** diffuse reflection sensor is a so-called fix focus diffuse reflection sensor. Its light beam excels due to its very low diffusion, with the result that small, even transparent objects may be detected. The smallest light spot diameter is found exactly in the centre of the nominal sensing range.

The mode of operation is based on the energetic principle. Consequently a considerably higher sensing range is achieved on bright or reflecting surfaces. The through-beam sensors can be supplied in different versions. Despite their small dimensions the maximum operating distance is up to 1m.

application examples

- ▶ presence check of different objects
- ▶ collision avoidance in feeding motions
- ▶ control of object and stack heights
- ▶ limit switches, position switches and pulse generators
- ▶ mounting on grippers

article-no.	OYQ30100	OYQ30103
version	through-beam sensor	through-beam sensor
connection	cable	cable
operating distance	150mm	1000mm

TECHNICAL DATA

operating distance	150mm	1000mm
minimum object size	non-transparent, Ø 1mm	non-transparent, Ø 2mm
output signal	pnp, dark-on mode **	pnp, dark-on mode **
operating voltage	12 ... 24V DC ± 10%	12 ... 24V DC ± 10%
current consumption (w/o load)	≤ 15mA *, ffi 10mA **	≤ 15mA *, ffi 10mA **
output current (max. load)	50mA **	50mA **
voltage drop (max. load)	1.0V DC **	1.0V DC **
transmitting element (pulsed)	LED, red light *	LED, red light *
wavelength	680nm *	680nm *
response time	max. 0.5ms	max. 0.5ms
hysteresis	-	-
repeat accuracy	0.05mm	0.05mm
display (signal)	red LED **	red LED **
display (stand-by)	green LED **	green LED **
short-circuit protection	+ **	+ **
reverse polarity protection	+	+
design	14.5x10x3.5mm	14.5x10x3.5mm
housing material	PET	PET
lens material	polyallylate	polyallylate
operating temperature	-25 ... +55°C	-25 ... +55°C
degree of protection (EN 60529)	IP67	IP67
connection	2m PVC-cable, 3-wire ** 2m PVC-cable, 2-wire *	2m PVC-cable, 3-wire ** 2m PVC-cable, 2-wire *
connection accessories	-	-
mounting accessories (bracket)	e.g. AV000077 / AV000078	e.g. AV000077 / AV000078

* transmitter
** receiver

through-beam, diffuse reflection sensors 1500

article-no.	OTQ30100	OTQ30170
version	diffuse reflection sensor	diffuse reflection sensor
connection	cable	M8-cable connector
sensing range	2 ... 25mm	2 ... 25mm
TECHNICAL DATA		
sensing range	2 ... 25mm	2 ... 25mm
minimum object size	Ø 1mm	Ø 1mm
output signal	pnp, light-on mode	pnp, light-on mode
operating voltage	12 ... 24V DC ± 10%	12 ... 24V DC ± 10%
current consumption (w/o load)	≤ 20mA	≤ 20mA
output current (max. load)	50mA	50mA
voltage drop (max. load)	1.0V DC	1.0V DC
transmitting element	LED, red light	LED, red light
wavelength	680nm	680nm
response time	< 0.5ms	< 0.5ms
hysteresis	15% of the sensing range	15% of the sensing range
repeat accuracy	0.1mm	0.1mm
display (signal)	red LED	red LED
display (stand-by)	green LED	green LED
short-circuit protection	+	+
reverse polarity protection	+	+
design	14.5x13x3.5mm	14.5x13x3.5mm
housing material	PET	PET
lens material	polyallylate	polyallylate
operating temperature	-25 ... +55°C	-25 ... +55°C
degree of protection (EN 60529)	IP67	IP67
connection	2m PVC-cable, 3-wire	M8-cable connector 300mm, 3-wire
connection accessories	-	e.g. VK200075
mounting accessories (bracket)	e.g. AV000077 / AV000078	e.g. AV000077 / AV000078

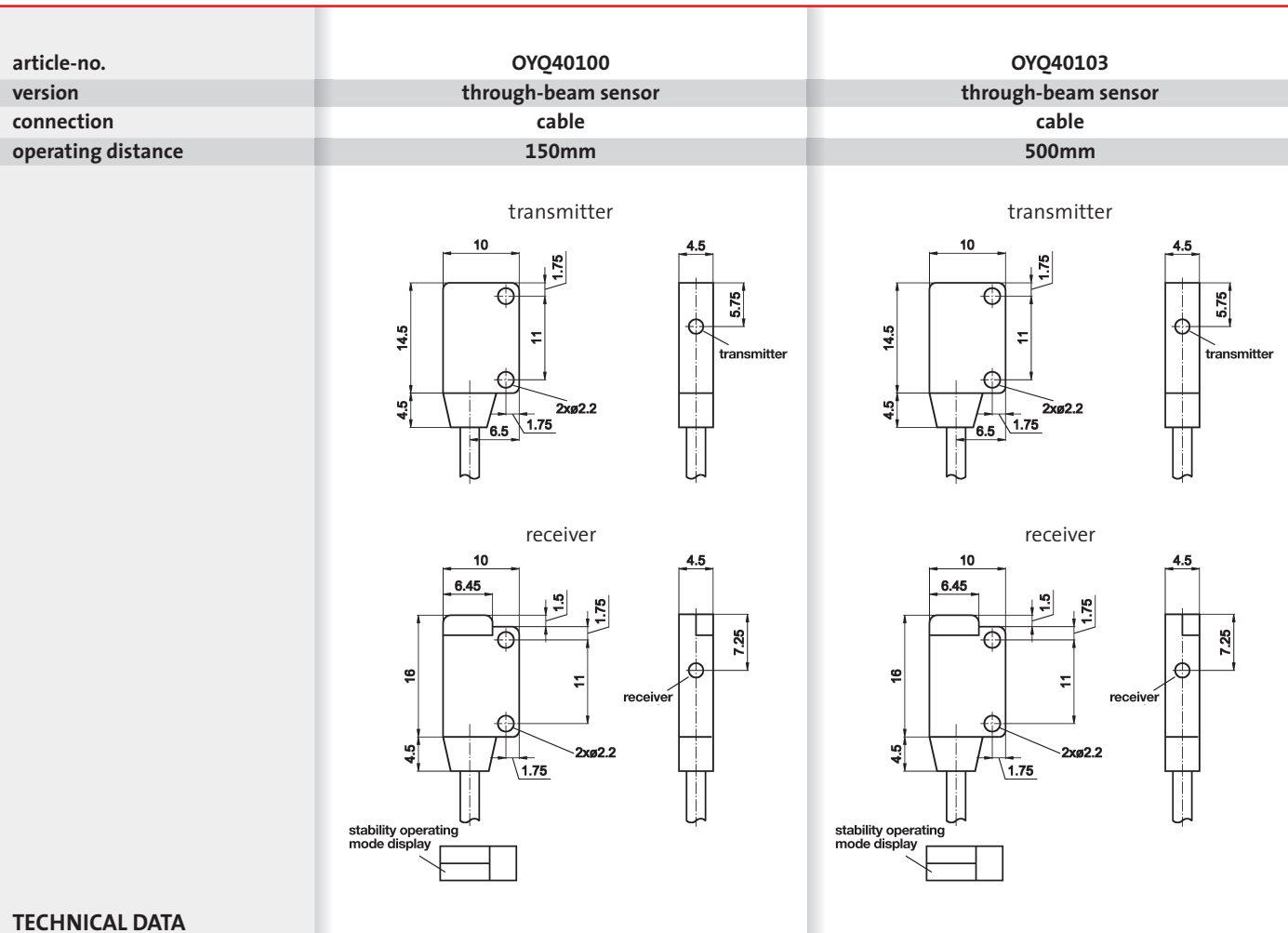

TECHNICAL DATA

operating distance	150mm	500mm
minimum object size	non-transparent, Ø 1mm	non-transparent, Ø 2mm
output signal	pnp, dark-on mode **	pnp, dark-on mode **
operating voltage	12 ... 24V DC ± 10%	12 ... 24V DC ± 10%
current consumption (w/o load)	≤ 15mA **, <=10mA *	≤ 15mA **, <=10mA *
output current (max. load)	50mA **	50mA **
voltage drop (max. load)	1.0V DC **	1.0V DC **
transmitting element (pulsed)	LED, red light *	LED, red light *
wavelength	680nm *	680nm *
response time	< 0.5ms	< 0.5ms
hysteresis	-	-
repeat accuracy	0.05mm	0.05mm
display (signal)	red LED **	red LED **
display (stand-by)	green LED **	green LED **
short-circuit protection	+ **	+ **
reverse polarity protection	+	+
design	14.5x4.5x10mm	14.5x4.5x10mm
housing material	PET	PET
lens material	polyallylate	polyallylate
operating temperature	-25 ... +55°C	-25 ... +55°C
degree of protection (EN 60529)	IP67	IP67
connection	2m PVC-cable, 3-wire ** 2m PVC-cable, 2-wire *	2m PVC-cable, 3-wire ** 2m PVC-cable, 2-wire *
connection accessories	-	-
mounting accessories (bracket)	e.g. AV000079	e.g. AV000079

* transmitter
** receiver

connection

transmitter

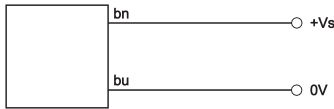

receiver

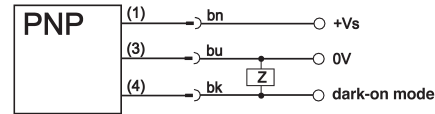

diffuse reflection sensors

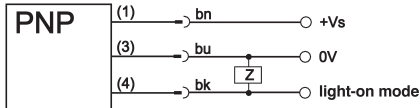

wire colors: bn = brown (1), bu = blue (3), bk = black (4)

mounting bracket AO000077 for OYQ3

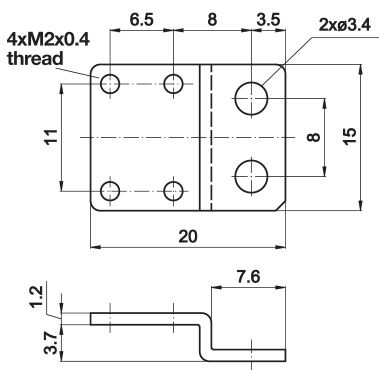

mounting bracket AO000078 for OYQ3

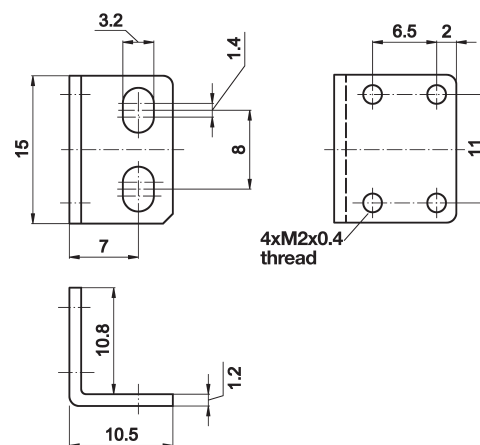

mounting bracket AO000079 for OYQ4

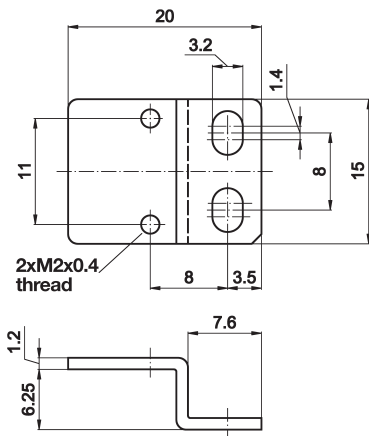

ACCESSORIES

article-no.	description	material
AO000077	mounting bracket OYQ3	galvanized sheet steel
AO000078	mounting bracket OYQ3	galvanized sheet steel
AO000079	mounting bracket OYQ4	galvanized sheet steel

This data sheet contains the standard versions only. Kindly request the availability of other output- and connection functions.

We will be pleased to supply the matching cable socket for your devices with connector. Please refer to the list in catalog chapter "accessories" under "cable sockets **ipf-SENSORFLEX**[®]" or search our website for "VK".

Warning: Never use these devices in applications where the safety of a person depends on their functionality.

This data sheet as well as your personal contact can be found at www.ipf-electronic.com

notes

export division

Kalver Straße 25 – 27
58515 Lüdenscheid
Germany

Fon +49 2351 98597-0
Fax +49 2351 98597-29

