



Safety for
men and machines



SLVARIO

Designer V340

Instruction manual

1. Contents

1. Contents	2
Product description	6
Version overview / Change history	6
1. System requirements	7
1.1. Installation	7
2. First steps	8
2.1. Hardware configuration	9
2.2. Arrange a rack	9
2.3. Delete module from the hardware configuration	10
2.4. Change slot	10
2.5. Open mask	10
3. Menu bar	11
3.1. File	11
3.1.1. New	11
3.1.2. Open	11
3.1.3. Recent files	11
3.1.4. Save	12
3.1.5. Save as	12
3.1.6. Print	12
3.1.7. Exit	12
3.2. Parameter	12
3.2.1. Tables	12
3.3. Project	12
3.3.1. Options	13
3.3.2. Application data	14
3.3.3. Statistic	14
3.3.4. Marker reference	15
3.3.5. Project comparison	15
3.3.6. Type label	15
3.3.7. System information	16
3.3.8. Project validation	16
3.3.9. Information	17
3.3.10. Checksum APP	17
3.3.11. Number of FB-Octets	17
3.3.12. SLW3-file compare	18
3.3.13. Search element	18
3.3.14. Password protection	18
3.4. View	19
3.5. Transmission	19
3.5.1. Transmit Application	19
3.5.2. Interface	20
3.6. Help	20
3.6.1. About SL-Vario	20
4. Navigation buttons	21
5. Logic circuit	22
5.1. Place an element	22
5.2. Gate properties (element properties)	23
5.3. Delete element/element group	23
5.4. Move an element group	23
5.5. Input→Duplicate	23
5.6. Abort placement	23
5.7. Wiring in the logic circuit	24
5.8. Delete a connection	24
5.9. Gate properties	24
5.10. Further functions in the circuit area	24
5.10.1. Insert label	25

- 5.10.2. Page name 25
- 5.10.3. Grid 25
- 5.10.4. Hide item labels 25
- 5.10.5. Hide line labels 26
- 5.10.6. Hide debouncing time 26
- 5.10.7. Hide Inverted outputs 26
- 5.10.2. Page arrangement 27
- 6. Rack-Diagnosis 27
- 7. Toolbar of the SL-Vario modules 28
 - 7.1. Overview elements from the main module 28
 - 7.2. Overview elements from the main module and the function modules 29
- 8. Logic elements from the main module 31
 - 8.1. Marker In and Marker Out 31
 - 8.2. AND / NAND gate (2x, 3x and 4x) 31
 - 8.3. OR / NOR gate (2x and 4x) 32
 - 8.4. XOR / XNOR gate 32
 - 8.6. Refeed element 33
 - 8.7. Start element 33
 - 8.8. RTDS (Restart lockout) 33
 - 8.9. RTSM 34
 - 8.10. RTSK 34
 - 8.11. Virtual 24V 34
 - 8.12. SLOK (SafeLine ok) 35
 - 8.13. Frequency synthesizer 35
 - 8.14. Watchdog-Trigger WDTR1 und WDTR2 36
 - 8.15. Operating mode selector SW 37
 - 8.16. Operating mode selector T 37
 - 8.17. Power on Reset 38
 - 8.18. Analog-Error 38
 - 8.19. Conversion factor 39
 - 8.20. Adder 39
 - 8.21. Subtractor 40
 - 8.22. Absolute subtractor 40
 - 8.23. Normalizer 41
 - 8.24. Analog Input Comparator 41
 - 8.25. Threshold switch 42
 - 8.26. Copier 42
- 9. Inputs on the SLVario modules 43
 - 9.1. Overview digital inputs 43
 - 9.2. Placement at the logic circuit 43
 - 9.3. Configurable In-/Outputs 44
 - 9.4. Analog inputs 44
 - 9.5. Analog Inputs for the safety-mat function 45
 - 9.6. Inputs for speed monitoring at the central module 45
- 10. Outputs on the SLVario modules 46
 - 10.1. Overview of the outputs 46
 - 10.2. Placement at the logic circuit 46
 - 10.3. Configurable semiconductor outputs 46
 - 10.4. Static semiconductor output 47
 - 10.5. Dynamical semiconductor output 47
 - 10.6. Clocked-output-couple 48
 - 10.7. Safety contact (relay) outputs on DNSL-ZMV 48
 - 10.8. Safety contact (relay) outputs on DNSL-ZMVK with output extension 49
 - 10.9. Analog Outputs on DNSL-ZMV/ZMVK 49
 - 10.10. Safety contact (relay) outputs on DNSL-RMV 50
- 11. Timer 51
 - 11.1. Function description 51
 - 11.2. OFF-delayed timer 51
 - 11.3. Example for an on-delayed timer 52

- 12. Counter (in preparation).....53
 - 12.1. Example for a counter.....54
- 13. Safety circuits.....55
 - 13.1. Digital inputs for the implementation of safety circuits55
 - 13.2. Configuration of the safety circuits55
 - 13.3. Logic circuit symbol of safety circuits56
- 14. Two-hand-control57
 - 14.1. Configuration for two-hand-control57
- 15. 1 OF N.....58
 - 15.1. Configuration58
- 16. Freely configurable logic elements59
 - 16.1. Configuration59
 - 16.2. Summarized Motion monitoring for 3 drives59
- 17. Guard door element61
- 18. Settings (Parameter – tables)62
 - 18.1. Configuration main module.....62
 - 18.1.1. Parameter ZMV62
 - 18.1.2. Connectors63
 - 18.1.3. Refresh63
 - 18.2. Parameter function modules.....63
 - 18.2.1. Connectors function modules64
 - 18.3. Parameter FB module FBV64
 - 18.3.1. Connector names of the input/output of FBV65
 - 18.3.2. FB-RT-Diag65
 - 18.4. Parameter NIV-module (in preparation)66
 - 18.5. Parameter SIV-module (in preparation).....66
 - 18.6. Parameter DSV/DRV-module66
 - 18.7. DNCO66
 - 18.8. Cam Parameter (in preparation).....66
- 19. Standstill and motion monitoring with proximity switch on main module67
 - 19.1. Inputs for motion monitoring on DNSL-ZMV67
 - 19.2. Proximity switch requirements.....67
 - 19.3. Configuration for one-channel-monitoring68
 - 19.4. Configuration for proximity switches.....68
 - 19.5. Configuration for a HTL-Measuring system.....69
 - 19.6. DZÜ (motion monitoring-) Parameter69
 - 19.7. Sens.monit. delay69
 - 19.8. Features on one-channel-monitoring.....69
 - 19.8.1. DZÜ Parameter about fieldbus.....69
- 20. Motion monitoring70
 - 20.1. General requirements to the measurement system (encoder).....70
 - 20.1.1. Incremental measurement system (TTL, HTL, Sin/Cos) with DNSL-DS70
 - 20.1.2. Resolver measurement system with DNSL-DR70
 - 20.1.3. SSI interface measurement system with DNSL-SIV70
 - 20.2. Configuration of motion monitoring.....70
 - 20.3. Inputs of the motion monitoring71
 - 20.4. Function of the virtual outputs of the rotation monitoring element71
 - 20.5. Parameter of the motion monitoring72
- 21. Position monitoring74
- 22. Direction monitoring with DNSL-DS, DR74
- 23. Brake monitoring with DNSL-DS75
- 24. DNCO-Function on DNSL-DS/DR76
 - 24.1. Digital inputs for DNCO function.....76
 - 24.2. Selection of the DNCO Function76
 - 24.3. Frequency tables DNCO 1 und DNCO 2.....77
 - 24.3.1. DNCO-Frequency selection about 4 inputs.....77
 - 24.3.2. DNCO-Frequency selection about 6 inputs.....78
 - 24.4. Example for DNCO Function80
 - 24.5. DNCO Function with Multiplexer81

25.	Fieldbus DNSL-FBV/DPV	82
25.1.	Configuration of the fieldbus inputs and outputs	82
25.2.	RTFB	83
25.3.	FB-Version-Information.....	83
26.	Muting	84
27.	Password protection for the application	85
27.1.	Options	85
27.2.	Responsibilities	85
27.3.	Change level.....	87
27.4.	Load an application which is password protected	87

SLVARIO DESIGNER

The direct way to safe automation

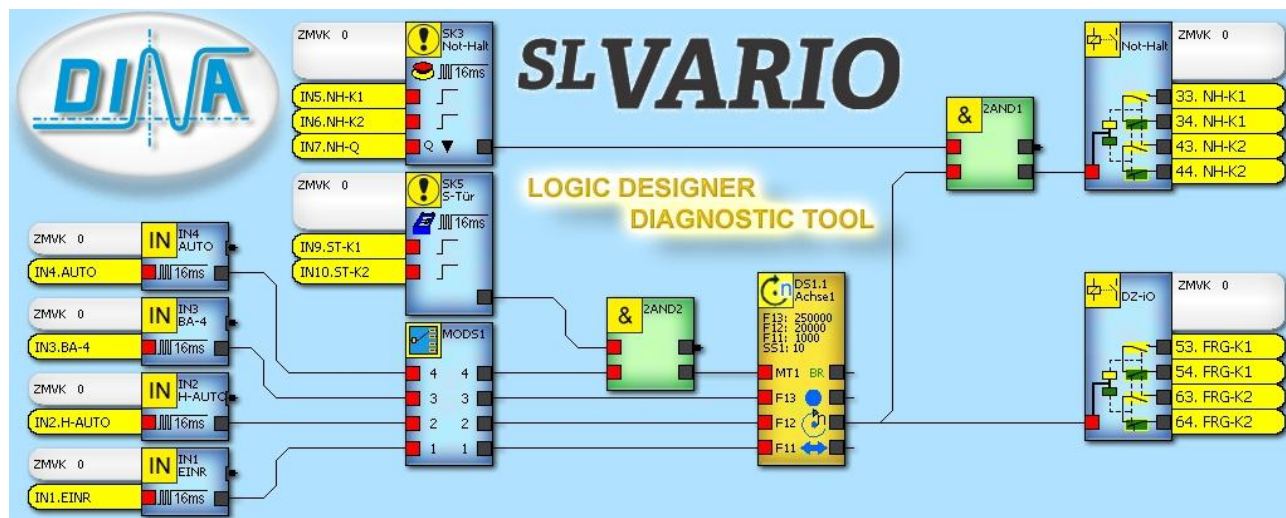

Product description

The graphical software **SLVARIO DESIGNER** enables the creation of a safety project for the DINA product line **SLVARIO**

An extensive library of standard and safety modules is available.

Both the inputs / outputs of the **SLVARIO** application-specific modules can link together, and safety functions such as emergency stop or speed controls are implemented.

Parameter tables offer a high flexibility.

The transfer of the project is made via the USB interface of the central module.

Afterwards extensive online diagnostic options are available.

Version overview / Change history

Version	Date	Innovations/Changes
0333	20.11.2013	Standard
0340	28.01.2014	Inverted terminals on HW- and SW- inputs, additional operating mode selector, PWR On Reset, 3AND Gate, guard door element, file compare, more marker

1. System requirements

Operating system: Windows XP, Windows Vista, Windows 7, Windows 8 (please contact the DINA support)

Memory min. 512MB

JAVA Runtime Environment (JRE): min. Version 6 Update 16

Connection cable from PC to SLVario-ZMV USB: cable no. 99SO11

1.1. Installation

Put the installation CD into the device. The program starts automatically.

Now install the USB driver software, which you also find on the installation CD under the name *SLVario_usb_Driver*. It contains fitted parameters.

To achieve the maximum transmission rate and the optimal speed of SLVario diagnosis an adjustment was performed.

This can lead to problems with other devices from the FTDI family. In this case, the following attitudes have to be changed for the affected device:

- Open the Device manager-> COM&LPT
- Select the USB Serial Port
- Open connection attitudes --> extended and increase the delay to 16ms

2. First steps

General definitions:

Left click: push the left mouse button

Right click: push the right mouse button

The communication interface is defined as COM port.

After installing all components, the program can be started.

Choose the language with left click on the flag.



Selection of language

The following mask appears. Right above you can find the Designer version number, the version date and the language.

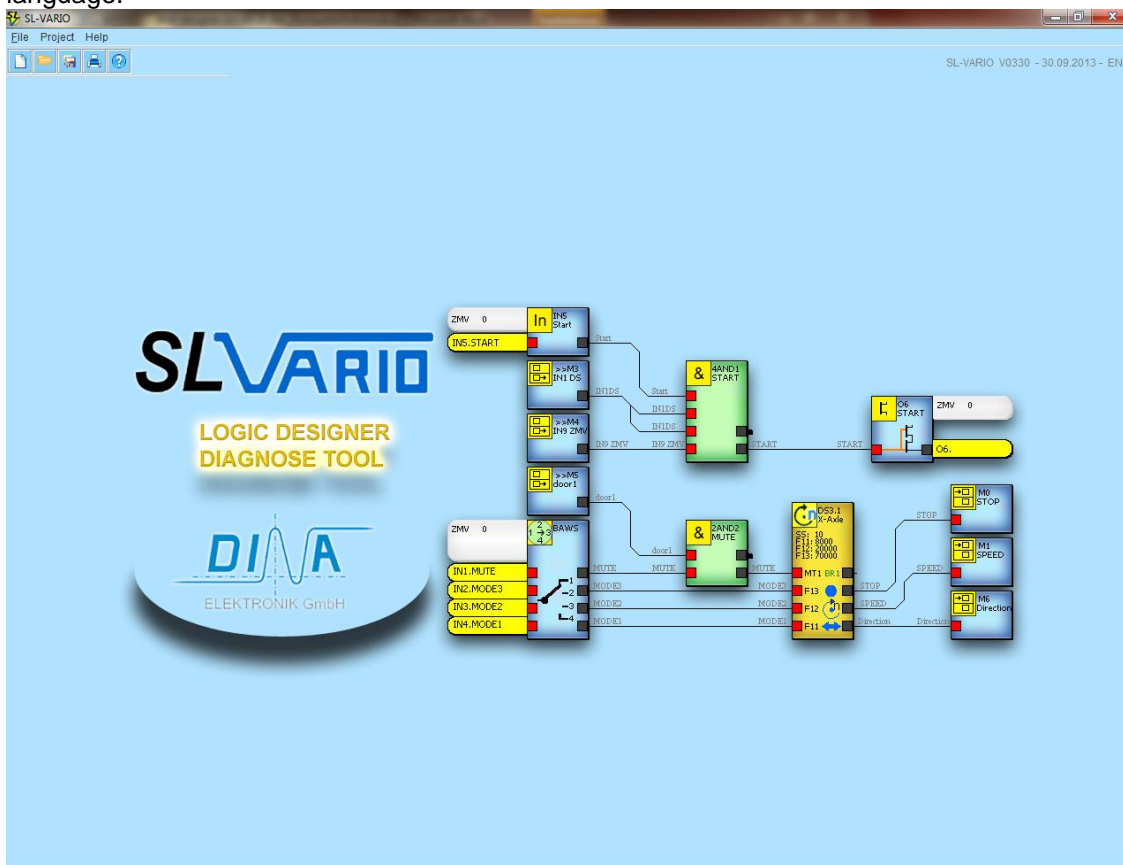

Designer mask

Left above different functions are available, described in capital [Menu bar](#).

To start a new project, click on the button .

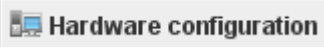
Now you can configure your rack by clicking on the button .

2.1. Hardware configuration

In the left frame you will find the available modules
 The middle frame (tree) shows the rack structure. The numbers 0...14 are according to the places (slot)
 The right frame represents the rack graphically. If no module is placed, an empty bus connector appears.

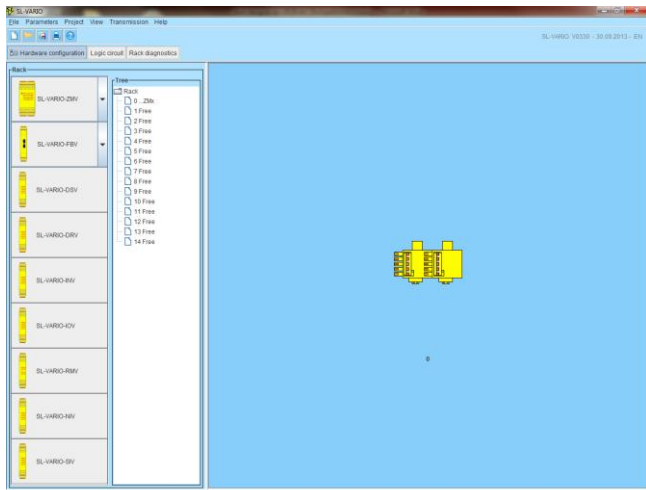

Hardware configuration

2.2. Arrange a rack

A main-module at the first place (Slot 0) is obligatory. The function modules can be arranged variable

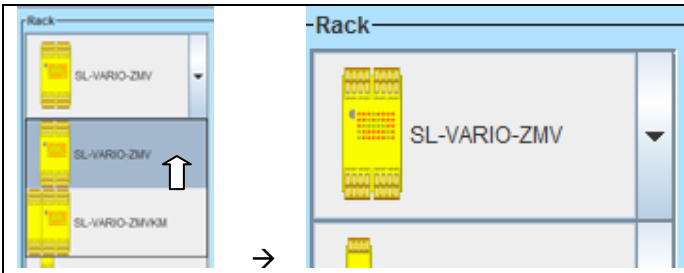
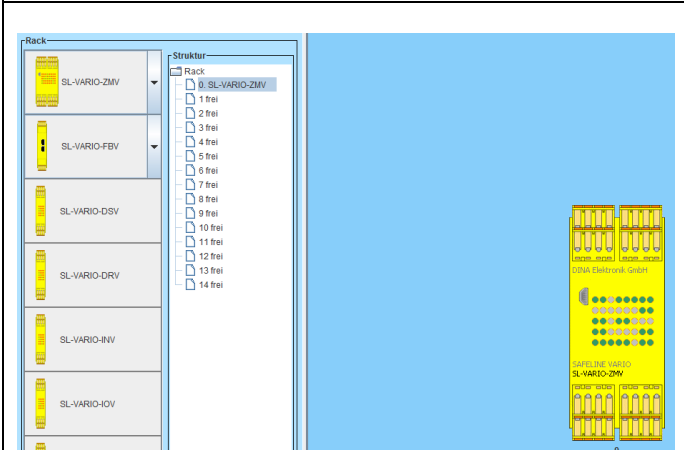
	<p>Two ZMV are available. The selection happens with the drop-down menu. Left click select the desired module.</p>
	<p>Using drag and drop the selected module can be dragged to the desired slot in the "Tree". The selected module is displayed graphically.</p>

	<p>Function modules haven't put on the slots continuously. In this case there is a difference between slot and slot number.</p> <p>In this example the DSV module get the slot no.2 although it is plugged in slot 1. The INV get the no. 4 although it is plugged in slot 2.</p>
--	---

2.3. Delete module from the hardware configuration

	<p>To remove a module, it must be marked.</p> <p>With the "DEL"-key or by right clicking it can be deleted. Select "Erase" in the drop-down-menu.</p> <p>⚠ Please note that the software elements from the module you want to delete will be deleted also in the logic circuit!</p>
--	--

2.4. Change slot

	<p>To change a slot, the desired module must be marked.</p> <p>With right click and selecting „change slot“ a new mask will be opened. The new slot will be marked with left click.</p> <p>The slot of the main module can't be changed.</p>
--	--

2.5. Open mask

	<p>To watch the parameters of a module, it must be marked.</p> <p>With right click and select „open mask“, the parameter mask appears.</p>
--	--

3. Menu bar

The following is a summary of the menu in the designer.

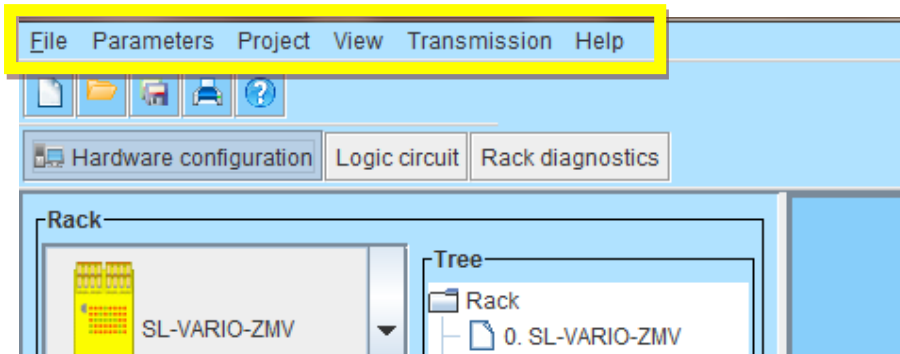

Menüleiste

3.1. File

The menu „file“ contains following selection.

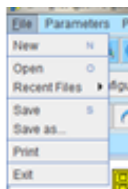

3.1.1.New

Start a new project. You may be asked whether the current project is to be saved.

3.1.2.Open

Open a saved project. The file extension from a Designer project file is „.slw3“. After opening, the file name appears in the first line of the designer mask.

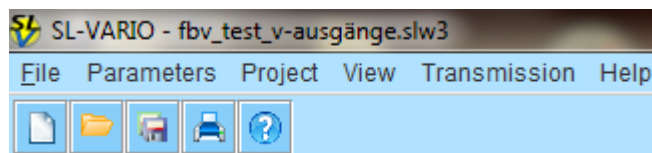

File without change

After changing the file, a "*" appears in front of the file name.

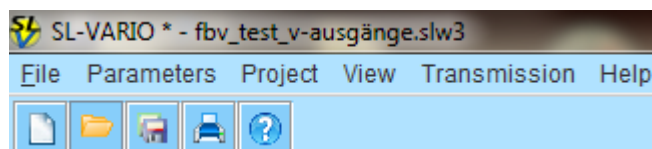

File with change

3.1.3.Recent files

The last 10 opened .slw3-files will be shown. After selecting, the project will be opened.

3.1.4. Save

Save the project on a selected path. The path can be changed in the menu Project - Options. The necessary settings can be found in chapter [Options](#).

3.1.5. Save as

Save the project under the selected path and file name.

3.1.6. Print

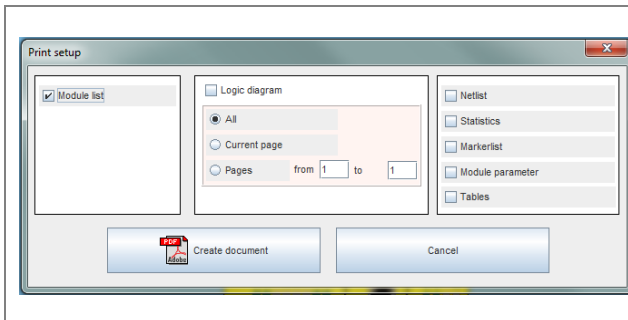

With the print option a .pdf-document can be generated. The document will open automatically. It will be saved in the same path as the project-file.

3.1.7. Exit

Close the program. You may be asked whether the current project is to be saved.

3.2. Parameter

The menu parameter contains following selection.

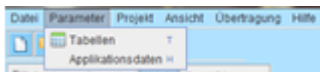

3.2.1. Tables

Here you will find the module parameters of the configured main module and the function modules. Further and detailed information about the parameters you will find in the chapter [Settings](#).

3.3. Project

The menu project contains following selection.

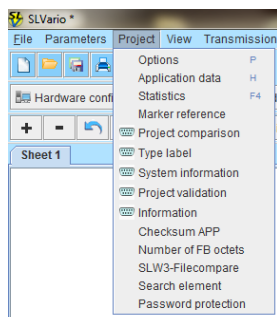

3.3.1.Options

Paths

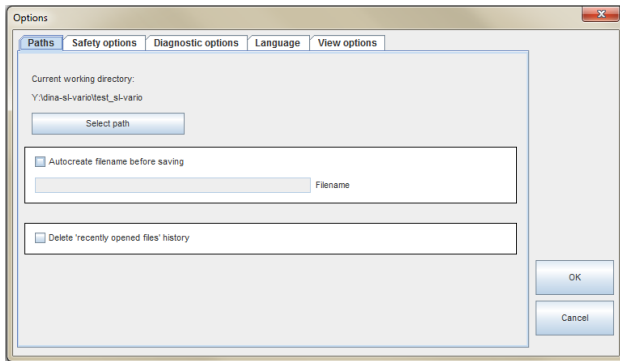

Current working path:

Here you can change the project path, which is set by default when you start the designer. The path will be taken over as new working path while saving a project.

Auto create filename before saving

Below you will find the possibility to generate an automatically name while saving, consisting of filename, date and time. E.g.:“mach1_D020910_T1409.slw3”. „mach1“ is the name which is typed in the box „filename”.

Delete „recently opened files“ history

The history of the recent opened files will be deleted.

Safety options

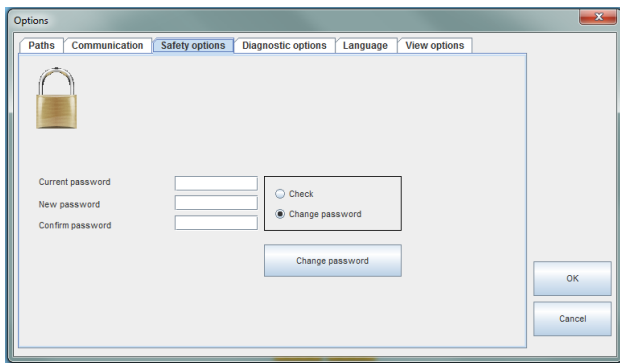

It is possible to protect the main module with a password. The password consists up to 8 characters (no special character, blanks, mutated vowel)

If the password is activated, the transfer of an application is not possible without first entering the correct password.

Check:

Here you can check the current password on the main module.

Type in the current password and push Check.

Change password:

Here you can set a new password to the connected main module. Type the actual password in the “Actual password”-field and the new password in the “New password”-field and confirm it in the “Confirm password”-field. Now click on the “Change password”-button.

If you want to delete the password, you have to type no characters in these fields.

Note: It is also possible to protect the application with passwords.

See Chapter [Password protection fort the application](#)

Diagnostic options

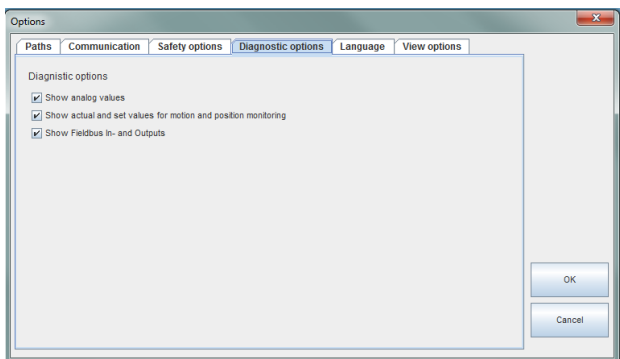

To speed up the online diagnostics, miscellaneous diagnostic functions can be deselected, if they are not relevant for debugging.

Show Analog values:

Analog Runtime values will be shown

Show actual and set values for position and speed monitoring.

The set and actual values for speed and position are displayed.

Show Fieldbus In-and Outputs:

The input and output information of the Fieldbus module are displayed.

Language

The currently available languages can be selected.

If the language is selected, a restart of the program is required.

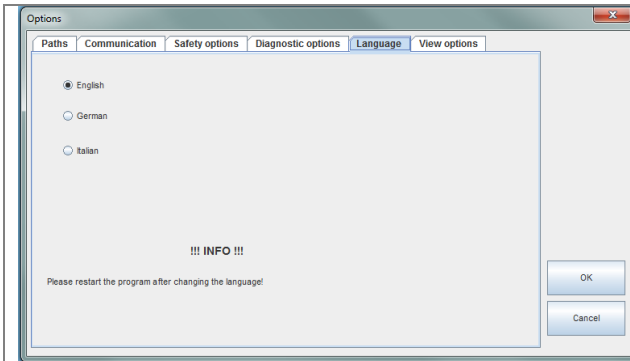

View options

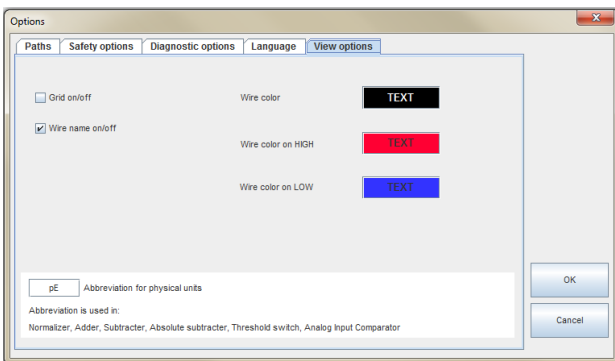

Several settings on the display options can be done. Here, some display options can be defined.

Grid on/off:

The grid is shown/not shown in the logic circuit.

Wire name on/off:

The name of a connection is shown/not shown in the logic circuit.

Wire color:

The color for a connection in the logic diagram in of-line/drawing mode.

Wire color on HIGH:

Color of the wire during Online diagnosis, if the logic level of the connection is on High-level.

Wire color on LOW:

Color of the wire during Online diagnosis, if the logic level of the connection is on Low-level.

Abbreviation for physical units

Is only relevant if the items listed below are used.

3.3.2. Application data

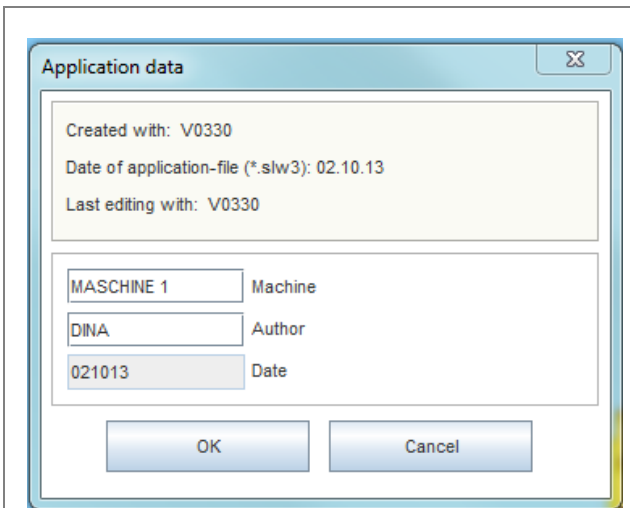

Here, machine-specific data (e.g. type of machine) and author are mentioned. These data are transferred to the main module and stored there

3.3.3. Statistic

The still available software elements are listed. Also you can see how many network list items, that mean connections between the logical elements, are available.

3.3.4.Marker reference

A list of the placed „Marker In“-elements will be created. Similarly, the page name and the corresponding number of „Marker Out“-elements will be displayed.

3.3.5.Project comparison

This operation requires the main module to be connected to the PC. The current project will be compared with the project stored on the connected main module. A message appears which shows you if the project in Designer and main module are the same, or not.

3.3.6.Type label

In SLVario main module an electronically type label is stored, which you can read out with this function. With left click on the field „Read out „,the relevant dates will be filled into the tables. Push „Print“to generate a document.

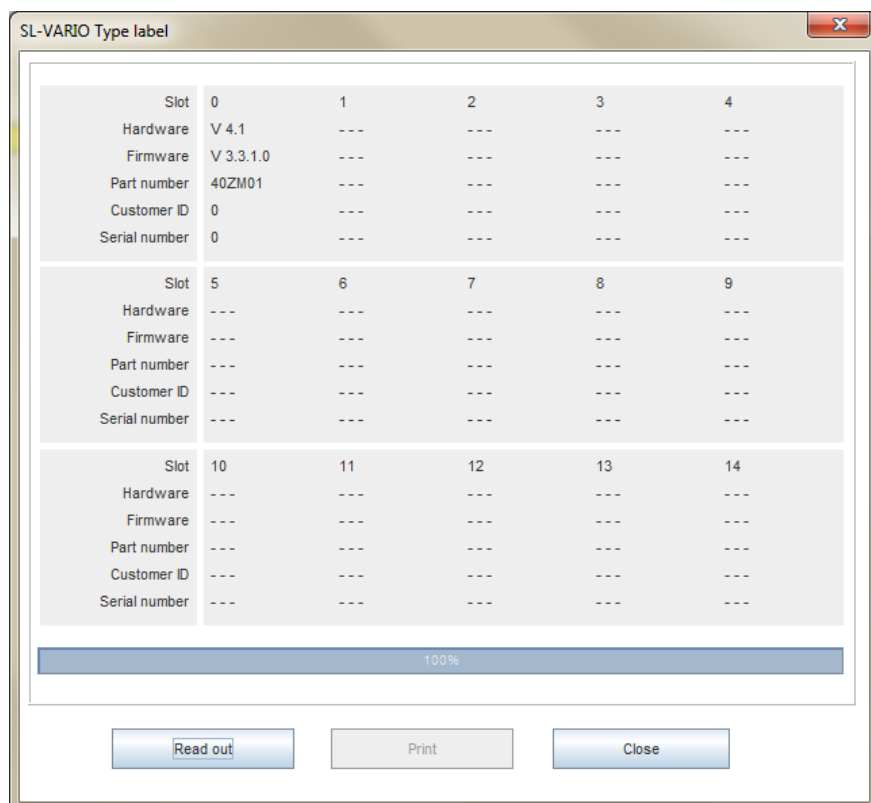

3.3.7. System information

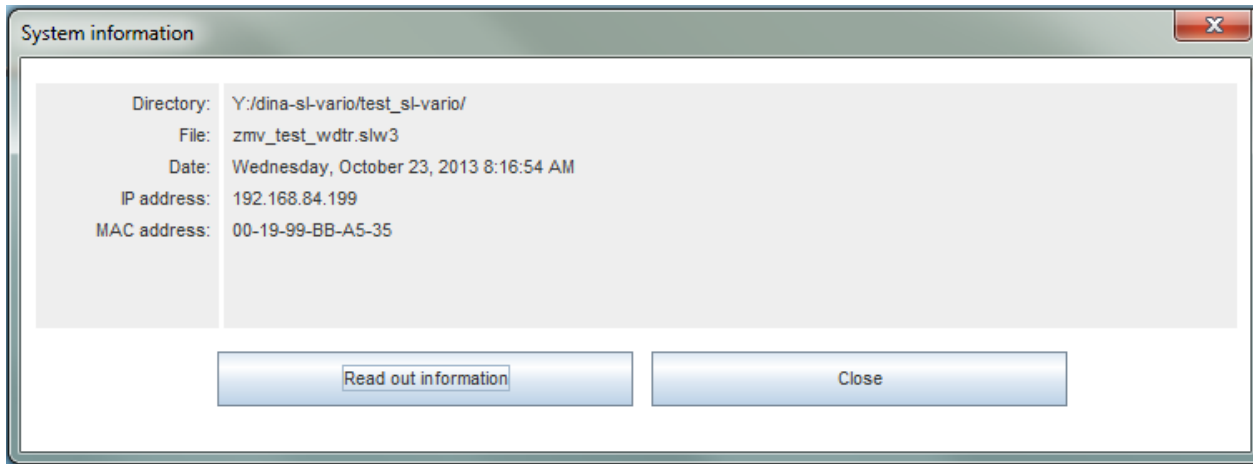

Here you can get information about the firmware of the connected main module.

- Path of the last transmitted application.
- File name of the last transmitted application
- Date and time of transmission
- IP- und MAC-address of the PC, from which the file has been transmitted.

3.3.8. Project validation

Here you can execute a validation of the project. After a successful validation automatically a documentation-file in PDF-format will be created and opened. All relevant validation information like checksum etc. is listed in the document- file. After validation is finished, you can read out the information at any time. Push the button „Read out validation information“.

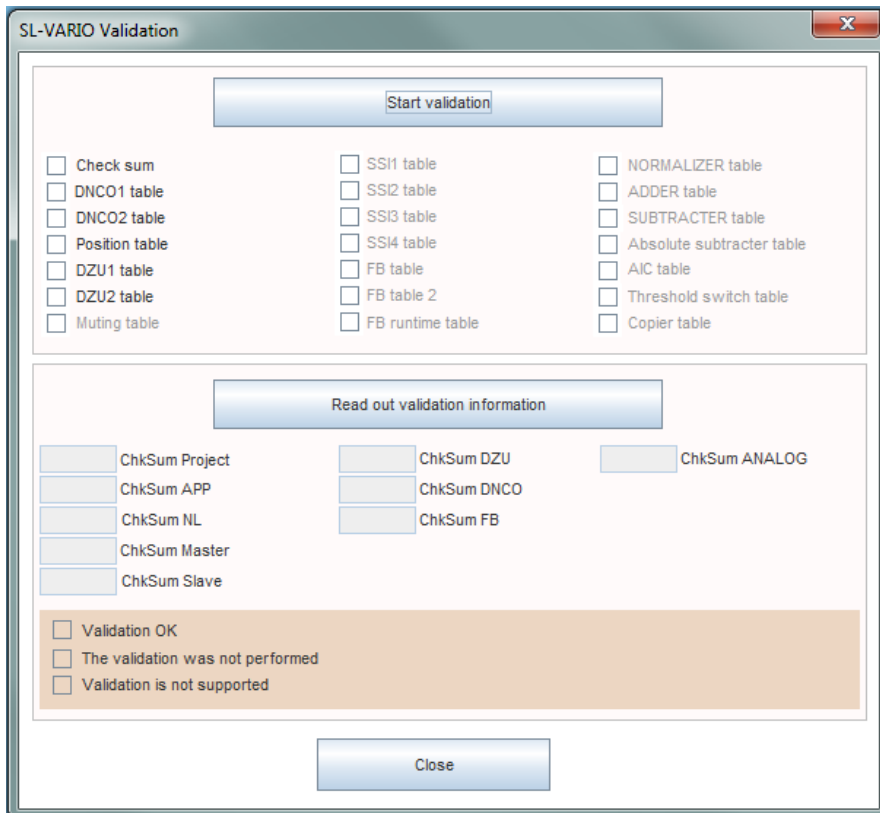

3.3.9. Information

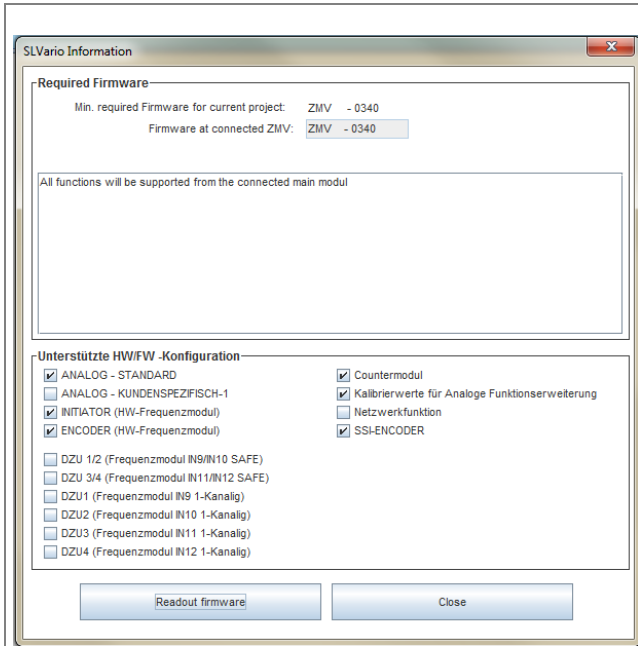

Here you can get information about the firmware of the connected main module and the available functions. With a click on the “Readout firmware”-button the firmware on the connected main module will be read out and compared with the required firmware for the current project. If you selected functions and/or placed which are not supported by the firmware, they will be listed.

3.3.10. Checksum APP

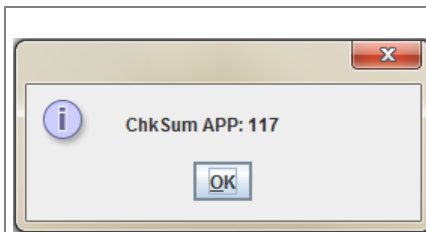

Here you can read out the checksum.

3.3.11. Number of FB-Octets

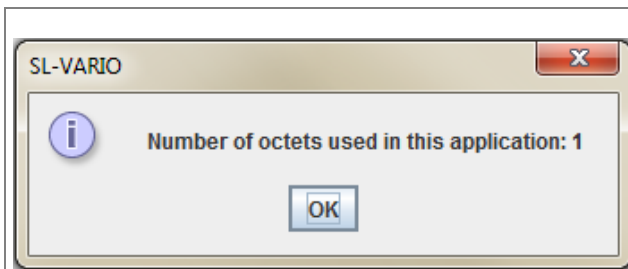

If your application contains a FBV module, here you can read out the number of the used octets.

3.3.12. SLW3-file compare

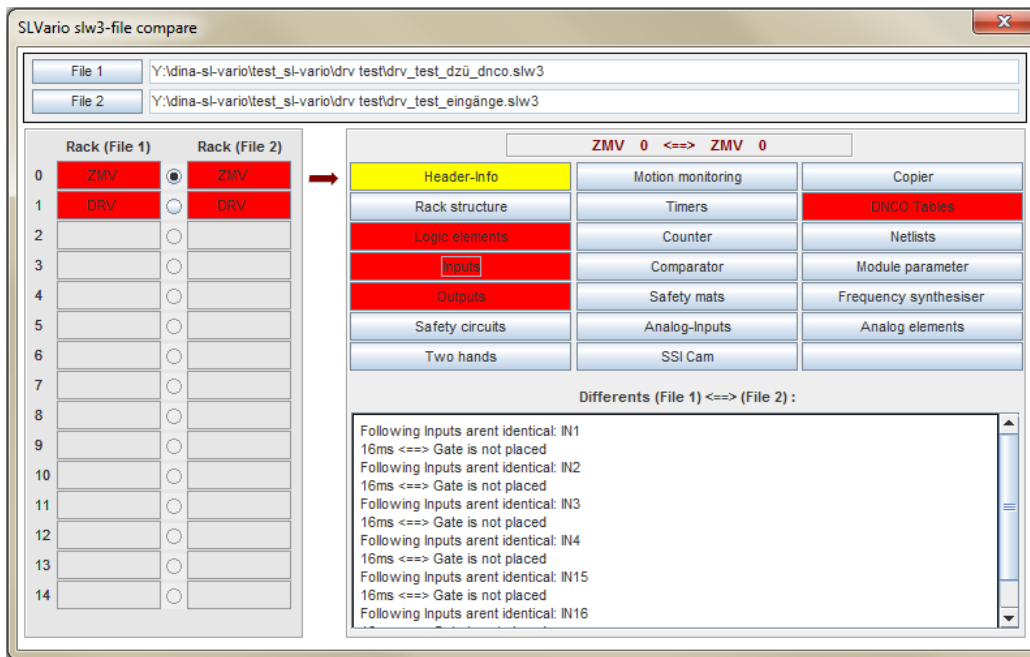

The file compare compares two applications.

First select the two files about the switching buttons file 1 and file 2. Then the program compares the files in the areas above. In the left box, each slot can be selected and compared using the button. Red areas indicate that there are differences. More detailed information is available by selecting the range area in right field and in the underlying information window.

3.3.13. Search element

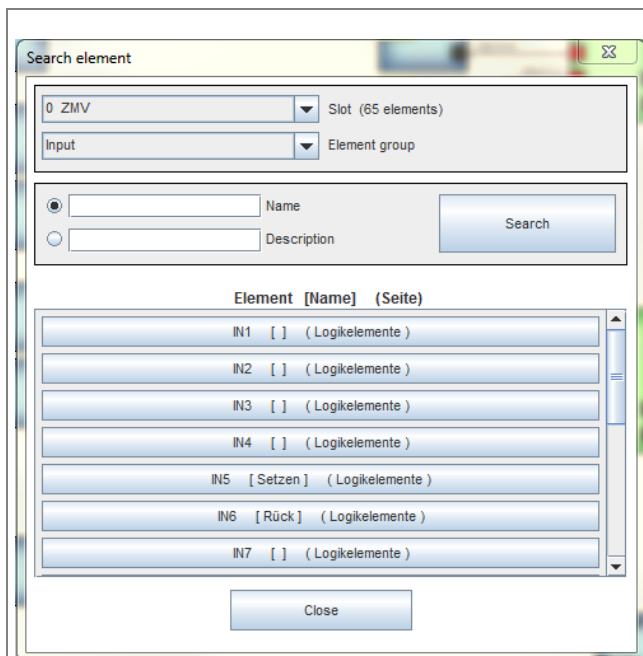

In this menu you can search special elements in your application. Although there are various search criteria available.

Slot: After left click on the pull down menu, a choice of the used modules appear. So you can choose a module. Every elements form this module will be shown in the pull down menu above.

Element group: After left click on the pull down menu, a choice of the used element groups appears.

After selecting the desired element group appears in the window all the elements used in this group with the name and the page on which the element has been configured.

Name/Description: By entering a name and / or description, and left click on SEARCH the element with this name appears in the bottom window. It is also possible to enter a part of a name or a description. Then a * must be entered as a wildcard, e.g. * door *.

3.3.14. Password protection

See chapter [Password protection for the application.](#)

3.4. View

Switch between the different windows like Hardware configuration, Logic circuit and Rack diagnosis



3.5. Transmission



3.5.1. Transmit Application

The generated application can be transmitted to the main module. The main module must be connected to the USB port. If the main module is correctly connected to the PC, the window "Transmit Application" appears.

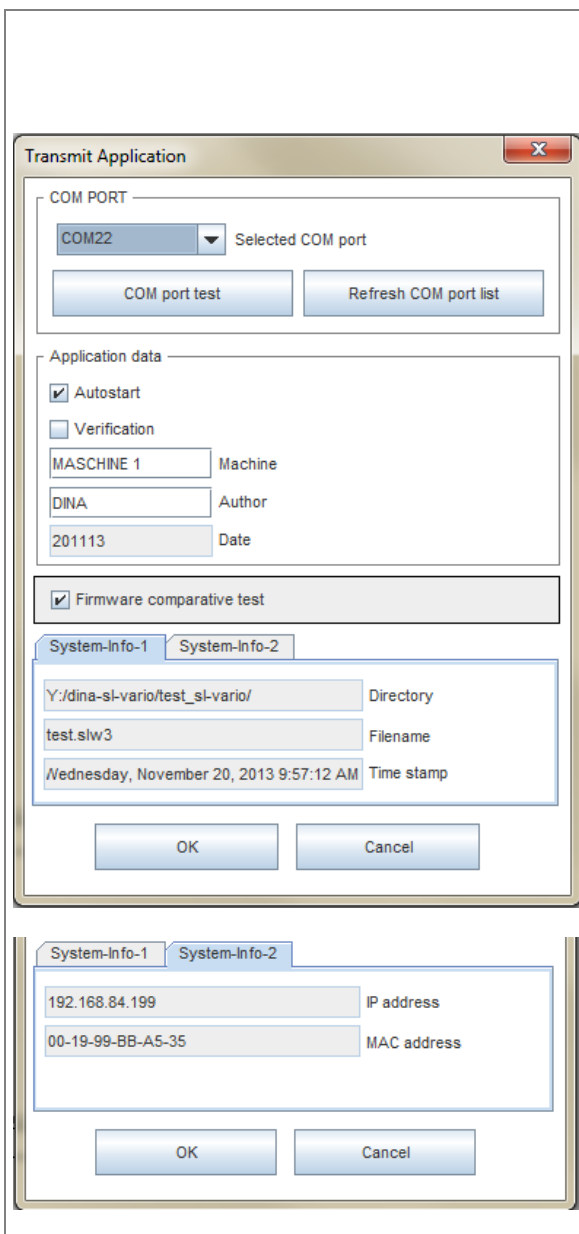

COM PORT

The COM port can be selected here.

COM-Port test:

Push the button to make a check, if the the main module is really connected at this COM port.

Refresh COM-Port List:

Shows the refreshed COM port list of the connected PC.

Autostart:

The main module is started automatically after the transmission.

Verification:

Verifies, if all dates are completely transmitted.

The verification excluded the autostart. The main module must be restarted (PWR off/on)

Machine, Author, Date

Input the description of

- the machine (max. 10 char.)
- the author (max. 6 char.)

The date will be generate automatically.

System-Info-1

This application-specific data is transmitted to the central module.

System-Info-2

	This PC-specific data is transmitted to the central module.
--	---

To start the transmission click on the "OK"-button.

3.5.2. Interface

The COM port can be selected here.

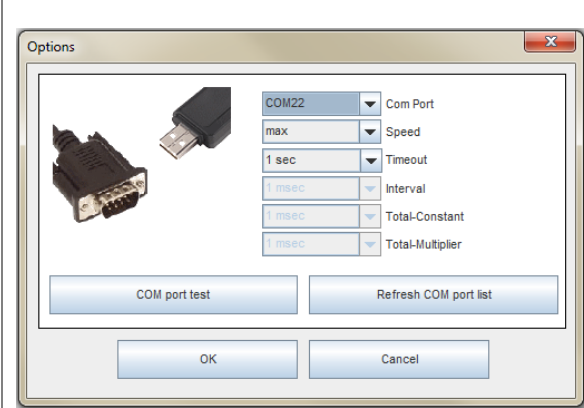
	<p>COM Port: Here you can set the COM port which you have connected the main module.</p> <p>Speed: On first start up you have to adapt this value to your pc.</p> <p>Timeout: If the diagnosis will be disturbed due to delays on the data line (e.g. via internet diagnostics, remote maintenance), then the timeout time can be raised to a stable value. Thus, the diagnosis is fault-tolerant of delays.</p>
---	---

3.6. Help

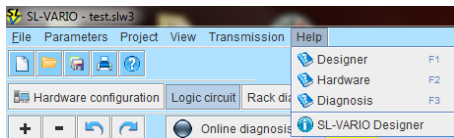

Open the help-files over the help-menu or with the hotkeys „F1“for the Designer help, „F2“for hardware help or „F3“for diagnosis help.

3.6.1. About SL-Vario

System information about the installed JAVA-version, operating system and Designer-version are displayed.



4. Navigation buttons

With the different buttons you can navigate between the different functional blocks, pages and the toolbars of the configured modules.

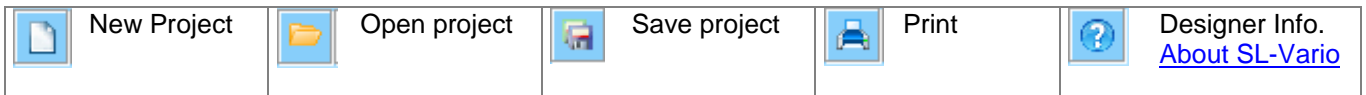
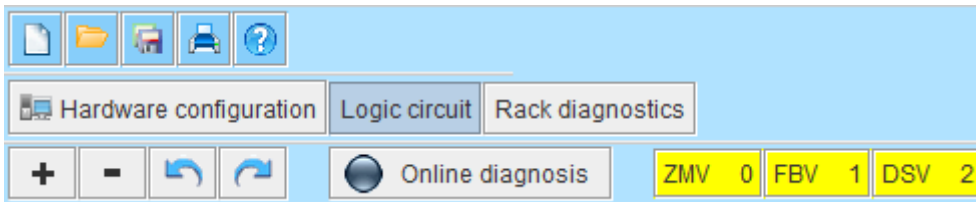

Hardware configuration Opens the hardware configuration	Logic circuit Opens the logic circuit	Rack diagnostics Opens the rack diagnosis. The main module has to be connected to the PC.	
--	--	--	--

Add a page	Delete a page	Undo	Redo	Online-Diagnose Start the Online diagnosis	ZMV 0 FBV 1 DSV 2 DSV 3
					Opens the toolbar from one of the configured module. The number on the right reflects the slot number where the module is configured.

5. Logic circuit

In this area you can develop your application. First the elements have to be placed. Then they must link together.

5.1. Place an element

To place an element, first you have to open the toolbar from the desired module with a left click.

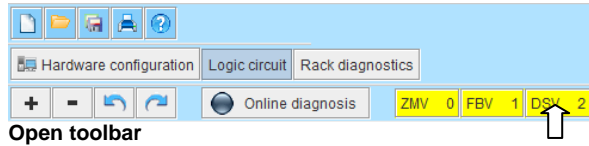

Depending on the module type, the toolbars are different. A selection appears, if you open the pull down menu of the desired element.

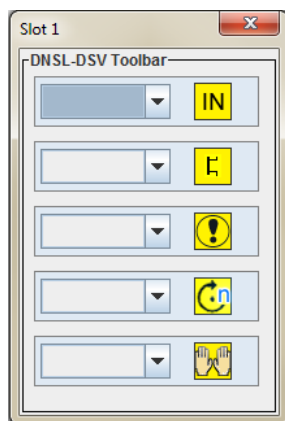

Toolbar DNSL-DSV

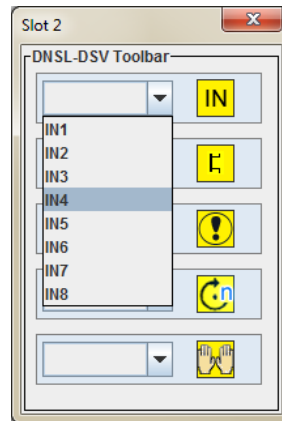

selection

After selection, a parameter field appears. This depends on the element. Here you can define the element with special parameters or just give them a name (max. 8 char.) or a description (max. 80 char.).

If the element is set, the name appears in the symbol. The description is shown, if you lead the mouse over the symbol.

The parameters are comment in the respective chapters.

The settings are saved with the button "OK". "Cancel" interrupt the process.

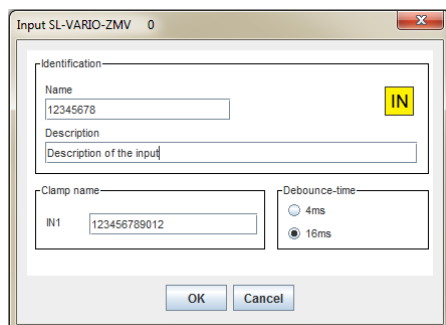

Example parameter field

With left click on „OK“, the symbol appears on the logic circuit. Now you can delay it on the desired place. Left click closes the action.

A further slide is done with left click, hold the taste and move the mouse. Left click on a free place finishes the action.

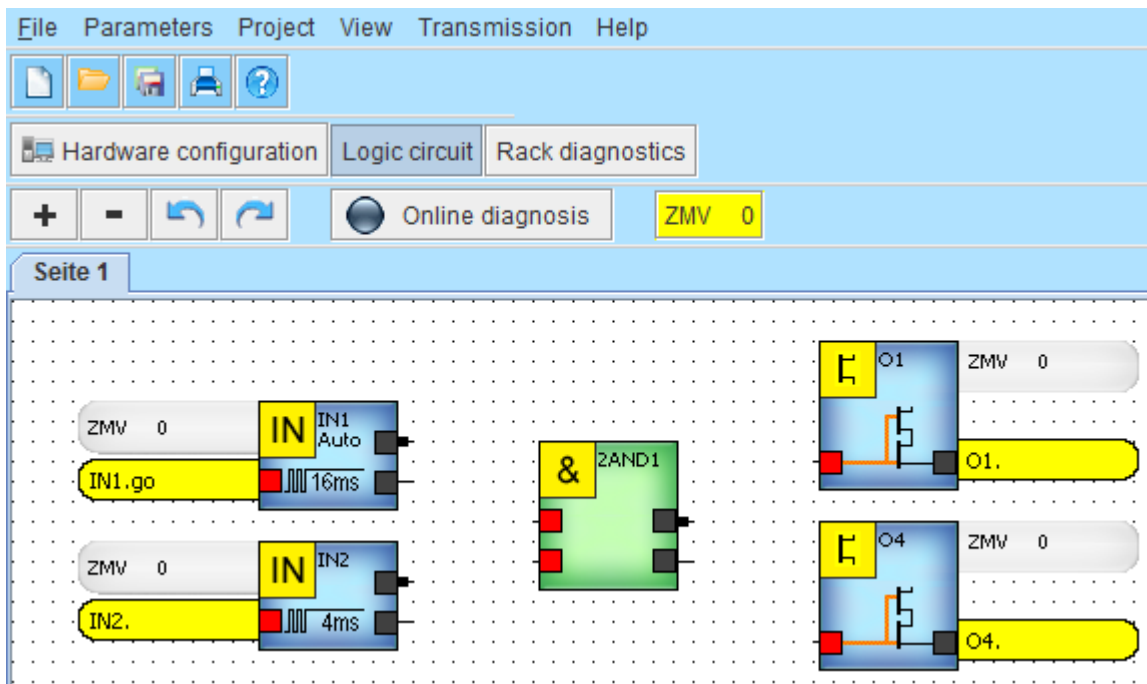

5.2. Gate properties (element properties)

If a placed element has parameters and/or configuration options, they can be opened by right-clicking on the element. A selection list appears. A click on “Gate properties” opens the properties window, if present.

5.3. Delete element/element group

If you want to delete a placed element, there are two possibilities:

- - Mark the element and press the “DEL”-key
- - Right-click on an element Choose “Remove”
- - Mark an element group: Left-click, hold the taste and describe a frame around the desired elements. Delete like a single element.

5.4. Move an element group

Mark an element group: Left-click, hold the taste and describe a frame around the desired elements. This group can move on this or to another page. Right click opens a new menu. Choose “move to...” and select the new page.

5.5. Input→Duplicate

If an input is placed on more pages, you can get a list about them.by right clicking on this input.

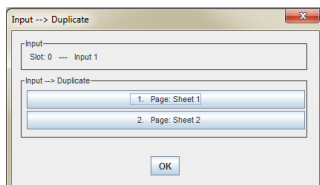

Duplicate

5.6. Abort placement

You can abort the placement of an element with the “ESC”-key.

5.7. Wiring in the logic circuit

350 network list items are available, that means 350 connections between the logical elements..

The wiring happens always from a virtual output to a virtual input

Example 1: automatic placing of the connection

The virtual output of the AND-gate will be clicked and then the virtual input "t" from the timer.

The system places the connection automatically.

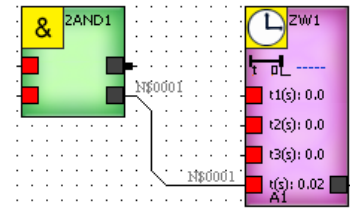

Example 2: manual placing of the connection

After a mouse click at the virtual outputs of the AND-gate, every angle points of the connection have to be clicked including the end of connection.

This method permits an accurate placing.

The point grid is an orientation guide.

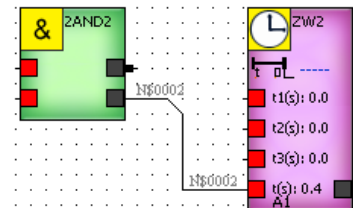

Example 3: Lineage of a connection

To place a second line, the virtual output of the AND gate have to click again. Then click the input of the marker.

The system places the connection automatically

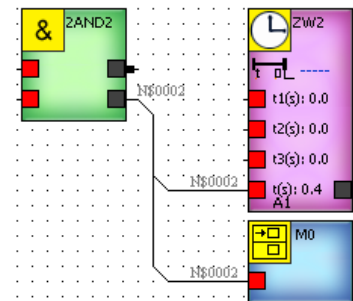

5.8. Delete a connection

While wiring, the connections can delete step by step with the „DEL“taste.

Connections, which are already in existence, can be deleted by right clicking and select „Remove wire“.

5.9. Gate properties

The properties of a connection can be recalled by right clicking and select „Gate properties“.

A wire can be defined with a name (max. 8 char.) and a description (max. 80 char.). The name appears at the wire in the logic circuit.

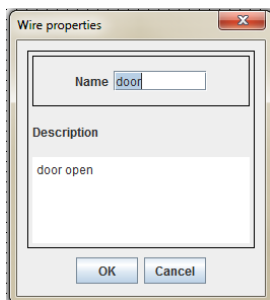

Properties

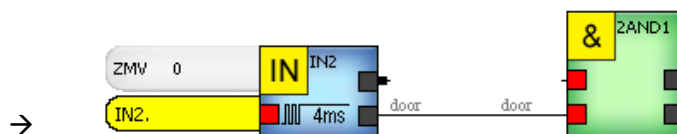

5.10. Further functions in the circuit area

A right click in a free area of the logic plan opens a box with the following options:

Insert label
Page name
<input type="checkbox"/> Grid
<input type="checkbox"/> Hide item labels
<input type="checkbox"/> Hide line labels
<input type="checkbox"/> Hide debouncing time
<input type="checkbox"/> Digital inputs: Hide inverted Output
<input type="checkbox"/> Mark Inputs that are already used in Toolbar
<input type="checkbox"/> Field bus inputs: Hide inverted Output
Page arrangement

5.10.1. Insert label

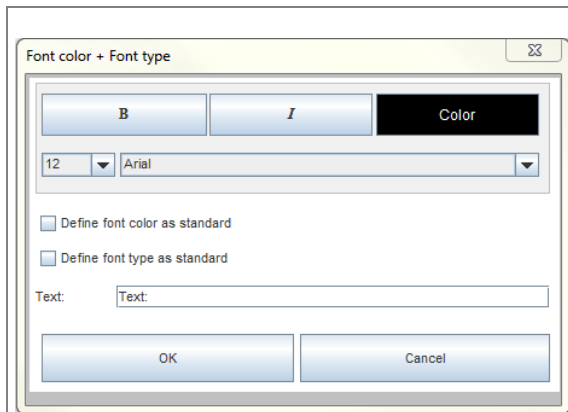

A click on “Insert label” opens a mask to enter a font, font size and color. In the field „Text” you can write a text for this label.

5.10.2. Page name

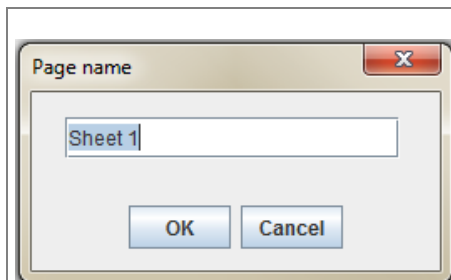

The current page can be described. (max. 40 char.)

5.10.3. Grid

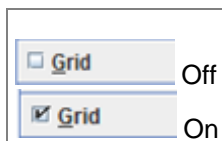

Switch the grid on or off.

5.10.4. Hide item labels

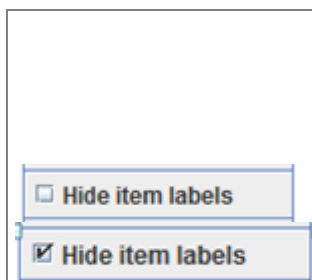

The labels, the name and the description of the items can be hidden.

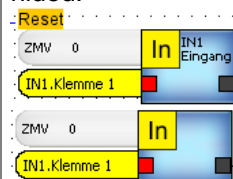

5.10.5. Hide line labels

Hide line labels

Hide line labels

The line labels can be hidden.

5.10.6. Hide debouncing time

Hide debouncing time

Hide debouncing time

The debouncing time can be hidden.

5.10.7. Hide Inverted outputs

Digital-Eingänge: Invertierten Ausgang ausblenden

FB-Eingänge: Invertierten Ausgang ausblenden

Digital-Eingänge: Invertierten Ausgang ausblenden

FB-Eingänge: Invertierten Ausgang ausblenden

The inverted outputs of the HW- and SW-inputs can be hidden.

5.10.1. Mark inputs that are already used in toolbar

Mark Inputs that are already used in Toolbar

Mark Inputs that are already used in Toolbar

Inputs that are already in use are identified in the toolbar with a "*" .

5.10.2. Page arrangement

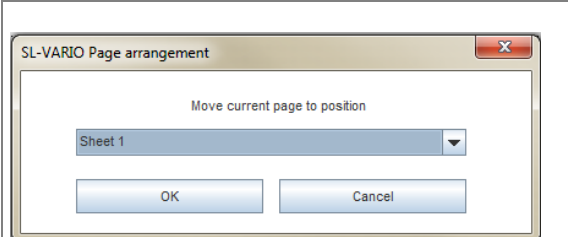
	<p>The page arrangement can be changed about the drop-down-menu.</p>
---	--









































6. Rack-Diagnosis









Further information about the rack diagnosis, you will find at the rack diagnosis help. The „F3“-key will opens help file.

7. Toolbar of the SL-Vario modules

The following is a summary of the available functions.

7.1. Overview elements from the main module

Toolbar	Elements → available numbers of this element
ZMV Toolbar 1	
	 Marker In → 100
	 Marker OUT → 100
	 2AND → 52 3AND → 10 4AND → 26
	 2-OR → 52 4-OR → 26
	 XNOR → 16
	 RS-Flip-Flop → 8
	 Refeed element → 16
	 Start element → 4
	 RTDS → 1
	 RTSM → 1
	 RTNI → 1 (in preparation)
	 RTSK → 1
	 virtual 24V
	 SLOK → 1
ZMV Toolbar 2	
	 Frequency synthesizer → 1
	 Watchdog-Trigger → 2
	 SW operating mode selector → 2
	 operating mode selector T → 1
	 Power on Reset → 1
	 Analog-Error → 1

ZMV Toolbar 3	
	Conversion factor → 1
	Adjuster → 1 (in preparation)
	Adder → 8
	Subtractor → 4
	Absolute Subtractor → 4
	Normalizer → 4
	Analog Input Comparator → 2
	Treshold switch → 8
	Copier → 4

7.2. Overview elements from the main module and the function modules

Element	ZMV/ ZMVKM	DSV/ DRV	INV	IOV	RMV	NIV	FBV DPV	SIV
 Input	✓ 16	✓ 8	✓ 12	✓ 8	✓ 8	✓ 8	✓ 8	✓ 8
 Semiconductor output	✓ 6	✓ 7	✓ 4 IO	✓ 7	-	✓ 4	-	✓ 4
 as Input or Output or Clocked- output-couple usable in pairs.	✓ 4	-	✓ 4	-	-	-	-	-
 Relay output	✓ 2/ 6	-	-	-	✓ 2	-	-	-
 Timer	✓ 15	-	-	-	-	-	-	-
 Counter ¹⁾	✓ 4	-	-	-	-	-	-	-
 Comparator ¹⁾	✓ 16	-	-	-	-	-	-	-
 Safety circuit	✓ 8	✓ 4	✓ 8	✓ 4	✓ 4	✓ 4	✓ 4	✓ 4

	✓ 2	✓ 1	✓ 1	✓ 1	✓ 1	-	✓ 1	-
Two-hand control								
	✓ 3 Über IN	✓ 2	-	-		-	-	✓ 2
Rotation monitoring								
	✓ 8	-	-	-	-	-	-	-
Safety-mat function								
	✓ 8 IN1-IN8	-	-	-	-	-	-	-
Analog-Input								
	✓ 2 O7, O8	-	-	-	-	-	-	-
Analog Output								
	✓ 64	-	-	-	-	-	-	-
Cam ¹⁾								
	✓ 2	-	-	-	-	-	-	-
1 of N								
	✓ 2	-	-	-	-	-	-	-
Multiplexer								
	✓ 8	-	-	-	-	-	-	-
Freely configurable logic elements								
	✓ 8	-	-	-	-	-	-	-
Guard door element								
	-	-	-	-	-	-	✓ 32	-
Virtual input								
	-	-	-	-	-	-	✓ 128	-
Virtual output								
	-	-	-	-	-	-	✓ 1	-
RTFB								
	-	-	-	-	-	-	✓ 1	-
FB-version information								
¹⁾ in preparation								

8. Logic elements from the main module

Over the toolbar of each module, the element can be selected and placed.

After selection, a parameter field appears. This depends on the element. Here you can define the element with special parameters or just give them a name (max. 8 char.) or a description (max. 80 char.).

If the element is set, the name appears in the symbol. The description is shown, if you lead the mouse over the symbol.

8.1. Marker In and Marker Out

Toolbar	Parameter field	Logic circuit symbol	Toolbar	Parameter field	Logic circuit symbol
<p>Marker In</p>			<p>Marker Out</p>	<p>After selecting a marker OUT, you must select the corresponding marker IN from the drop-down box.</p>	

The virtual output of a +24V-element could not be connected to a marker IN. The marker OUT cannot be left open, they must be wired in the Logic circuit. It is not possible to connect a marker input directly to a marker output. Alternatively, you can achieve this by using an OR-element.

8.2. AND / NAND gate (2x, 3x and 4x)

Toolbar	Parameter field	Logic circuit symbol	description																				
		<p>2 Inputs</p> <p>3 inputs</p> <p>4 Inputs</p>	<table border="1"> <thead> <tr> <th>A</th> <th>B</th> <th>Y</th> <th>/Y</th> </tr> </thead> <tbody> <tr> <td>0</td> <td>0</td> <td>0</td> <td>1</td> </tr> <tr> <td>0</td> <td>1</td> <td>0</td> <td>1</td> </tr> <tr> <td>1</td> <td>0</td> <td>0</td> <td>1</td> </tr> <tr> <td>1</td> <td>1</td> <td>1</td> <td>0</td> </tr> </tbody> </table> <p>Input A Input B Output Y Negated output /Y </p>	A	B	Y	/Y	0	0	0	1	0	1	0	1	1	0	0	1	1	1	1	0
A	B	Y	/Y																				
0	0	0	1																				
0	1	0	1																				
1	0	0	1																				
1	1	1	0																				

8.3. OR / NOR gate (2x and 4x)

Toolbar	Parameter field	Logic circuit symbol	description																				
		<p>2 Inputs</p> <p>4 Inputs</p>	<table border="1"> <thead> <tr> <th>A</th> <th>B</th> <th>Y</th> <th>/Y</th> </tr> </thead> <tbody> <tr> <td>0</td> <td>0</td> <td>0</td> <td>1</td> </tr> <tr> <td>0</td> <td>1</td> <td>1</td> <td>0</td> </tr> <tr> <td>1</td> <td>0</td> <td>1</td> <td>0</td> </tr> <tr> <td>1</td> <td>1</td> <td>1</td> <td>0</td> </tr> </tbody> </table> <p>Input A Input B Output Y Negated output /Y (corresponds a NOR)</p>	A	B	Y	/Y	0	0	0	1	0	1	1	0	1	0	1	0	1	1	1	0
A	B	Y	/Y																				
0	0	0	1																				
0	1	1	0																				
1	0	1	0																				
1	1	1	0																				

8.4. XOR / XNOR gate

Toolbar	Parameter field	Logic circuit symbol	description																				
			<table border="1"> <thead> <tr> <th>A</th> <th>B</th> <th>Y</th> <th>/Y</th> </tr> </thead> <tbody> <tr> <td>0</td> <td>0</td> <td>1</td> <td>0</td> </tr> <tr> <td>0</td> <td>1</td> <td>0</td> <td>1</td> </tr> <tr> <td>1</td> <td>0</td> <td>0</td> <td>1</td> </tr> <tr> <td>1</td> <td>1</td> <td>1</td> <td>0</td> </tr> </tbody> </table> <p>Input A Input B Output Y Negated output /Y (corresponds a XOR)</p>	A	B	Y	/Y	0	0	1	0	0	1	0	1	1	0	0	1	1	1	1	0
A	B	Y	/Y																				
0	0	1	0																				
0	1	0	1																				
1	0	0	1																				
1	1	1	0																				

8.5. RS Flip-Flop

Toolbar	Parameter field	Logic circuit symbol	description																				
			<table border="1"> <thead> <tr> <th>S</th> <th>R</th> <th>Q</th> <th>/Q</th> </tr> </thead> <tbody> <tr> <td>0</td> <td>0</td> <td>0</td> <td>1</td> </tr> <tr> <td>0</td> <td>1</td> <td>0</td> <td>1</td> </tr> <tr> <td>1</td> <td>0</td> <td>1</td> <td>0</td> </tr> <tr> <td>1</td> <td>1</td> <td>0</td> <td>1</td> </tr> </tbody> </table> <p>S: Set R: Reset</p> <p>The reset input is prior.</p>	S	R	Q	/Q	0	0	0	1	0	1	0	1	1	0	1	0	1	1	0	1
S	R	Q	/Q																				
0	0	0	1																				
0	1	0	1																				
1	0	1	0																				
1	1	0	1																				

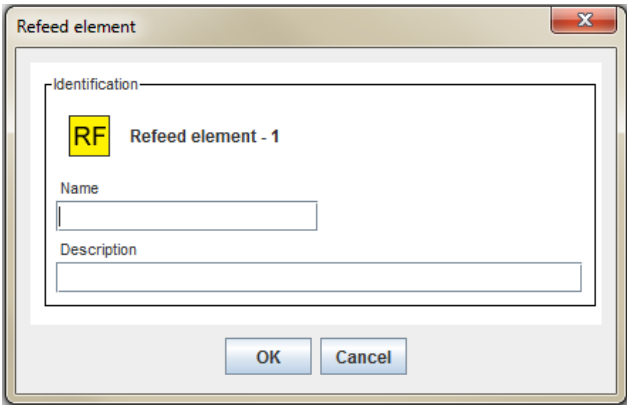
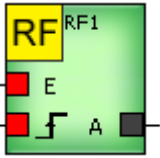
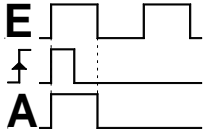

8.6. Refeed element

Toolbar	Parameter field	Logic circuit symbol	description
			<p>Function diagram</p> 

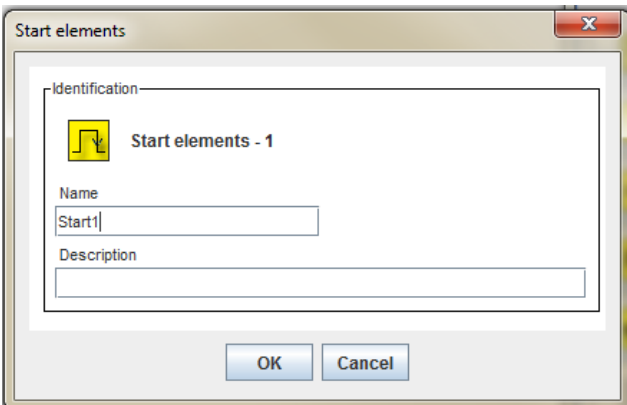
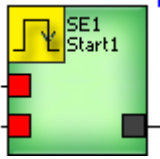
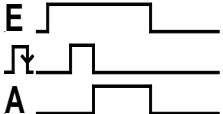

8.7. Start element

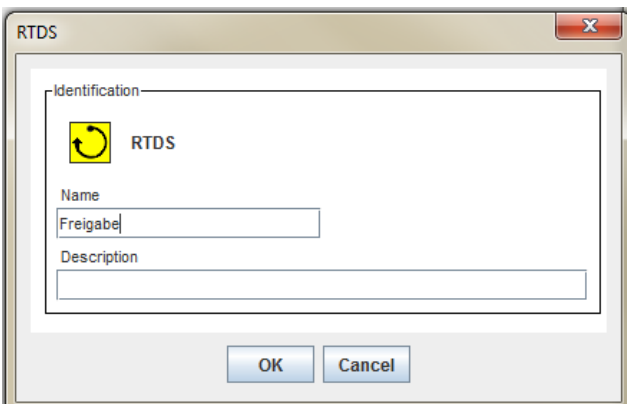
Toolbar	Parameter field	Logic circuit symbol	description
			<p>Function diagram</p> 

8.8. RTDS (Restart lockout)

Toolbar	Parameter field	Logic circuit symbol	description
			<p>Acknowledgement of the restart lockout. The element can only be placed once.</p> <p>The virtual input of the RTDS-Function is used to quit the emergency stop status of a machine. See chapter motion monitoring</p>

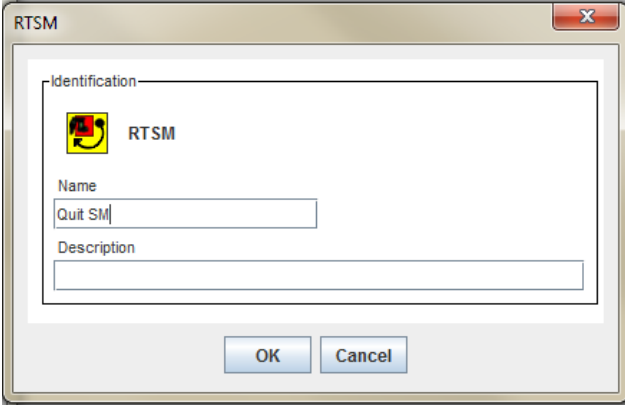

8.9. RTSM

Toolbar	Parameter field	Logic circuit symbol	description
			<p>Acknowledgement of the restart lockout by safety mats.</p> <p>The element can only be placed once.</p> <p>The virtual input of the RTSM-Function is used to quit the emergency stop status of safety mats monitoring.</p> <p>See chapter Analog Inputs for safety mats</p>

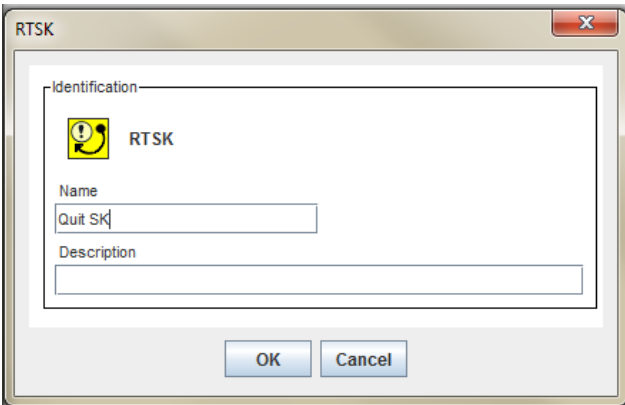
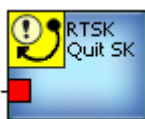

8.10. RTSK

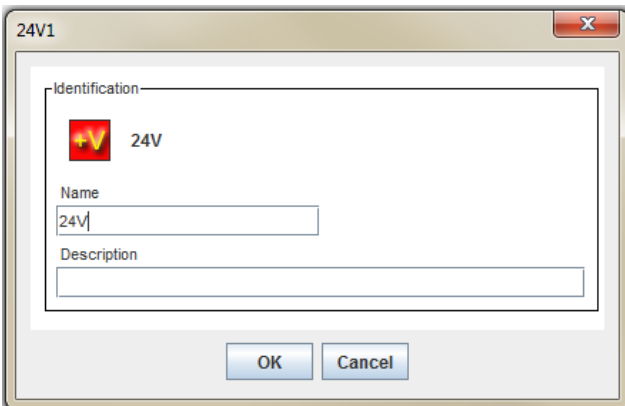
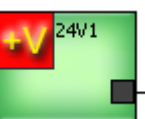
Toolbar	Parameter field	Logic circuit symbol	description
			<p>Acknowledgement of the error messages of the safety circuits and the latch function.</p> <p>The element can only be placed once.</p> <p>The virtual input is used to quit error messages by safety circuits. The acknowledgement happens with falling edge.</p> <p>See chapter Safety circuits</p>

8.11. Virtual 24V

Toolbar	Parameter field	Logic circuit symbol	description
			<p>This element can be used to connect virtual inputs from each element.</p> <p> It is not possible to connect the output of the element to the input of a marker-IN-element.</p>

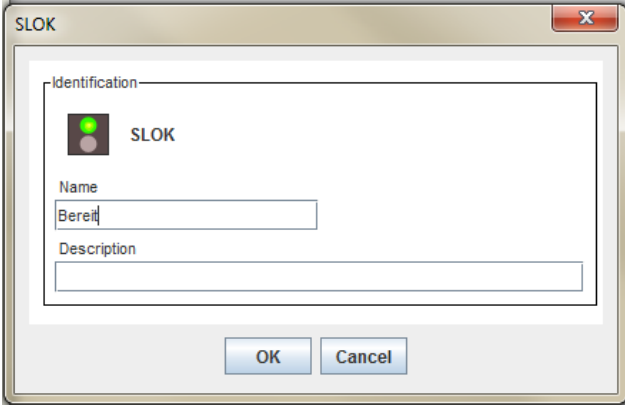

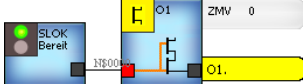
8.12. SLOK (SafeLine ok)

Toolbar	Parameter field	Logic circuit symbol	description
			<p>The operation state from SL-Vario can be shown in relation with an output.</p>  <p>The element can only be placed once.</p>

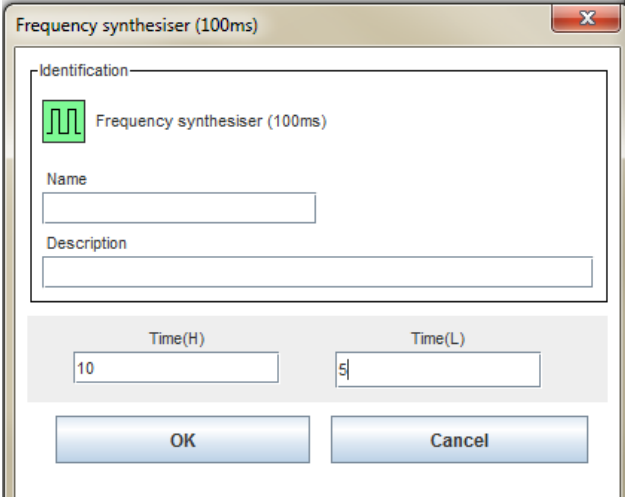
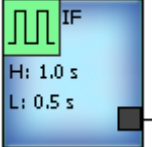
8.13. Frequency synthesizer

Toolbar	Parameter field	Logic circuit symbol	description
			<p>The element can only be placed once. High and low signals are separately adjustable in 100ms steps. 1=100ms up to 255=25,5s is the highest possible value.</p>

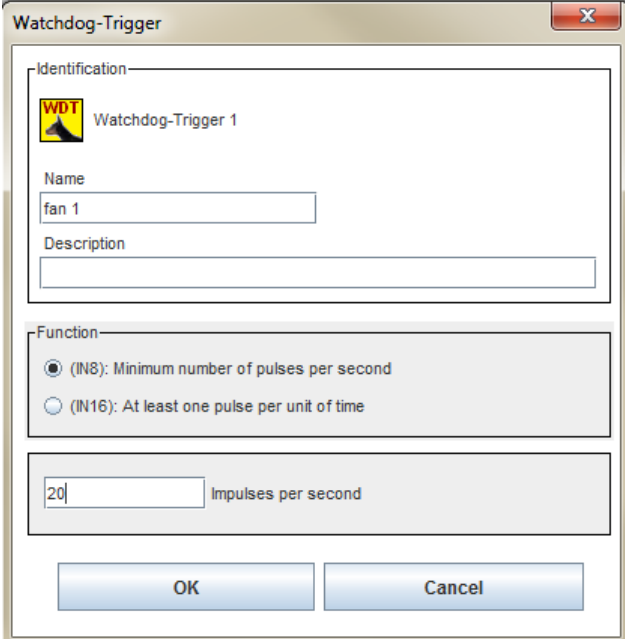
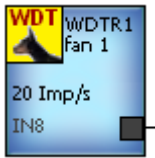
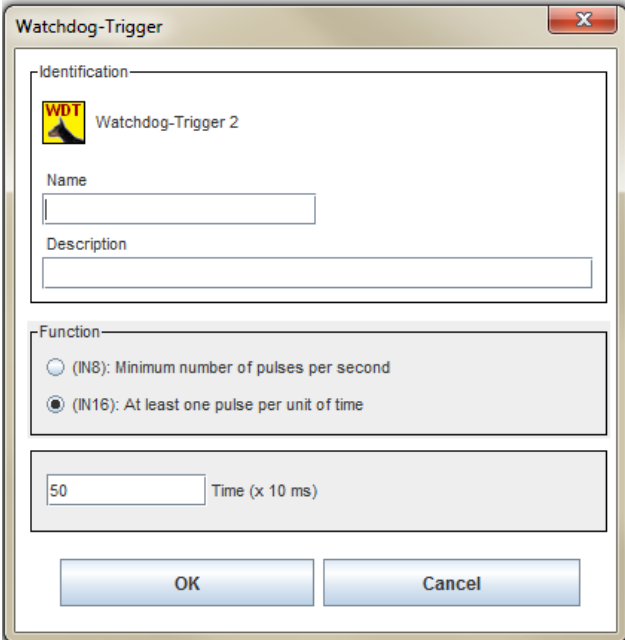
8.14. Watchdog-Trigger WDTR1 und WDTR2

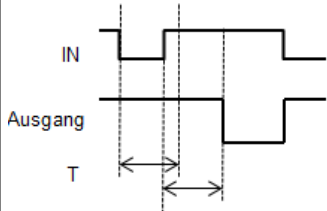
Toolbar	Parameter field	Logic circuit symbol	description
			<p>The Watchdog-Trigger WDTR1 checks the number of pulses per second at the input 8. The home position of the output is high. It is low, if the pulses are less than the required number. It switches automatically on, if the required number is reached.</p>
			<p>The Watchdog-Trigger WDTR2 checks, if one pulse per unit of time occurs on input 16. The unit of time will be calculated with the entered factor (1...255) multiplied by 10ms. The home position of the output is high. It is off, if there is no pulse in this unit of time. It switches automatically on, if there is a revival pulse.</p>  <p>Mark: The LED of IN8 and IN16 is equivalent to the output of the WDTR.</p>

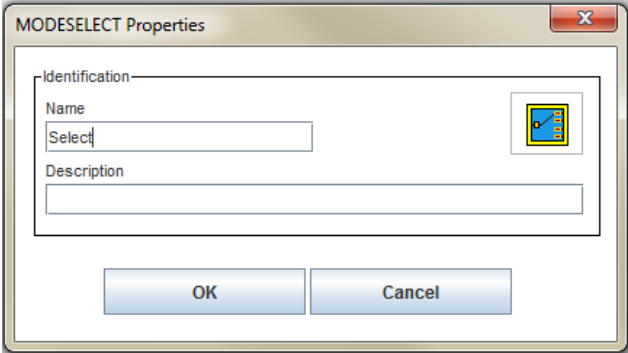
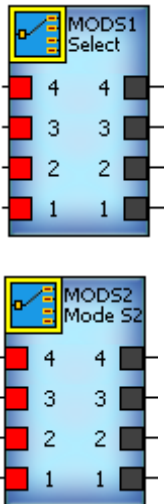

8.15. Operating mode selector SW

Toolbar	Parameter field	Logic circuit symbol	description
			<p>MODE-SLCT-1/2: According to the selected input, the corresponding output goes HIGH. All other outputs are LOW. If more than one input is selected, all outputs switch to LOW</p>

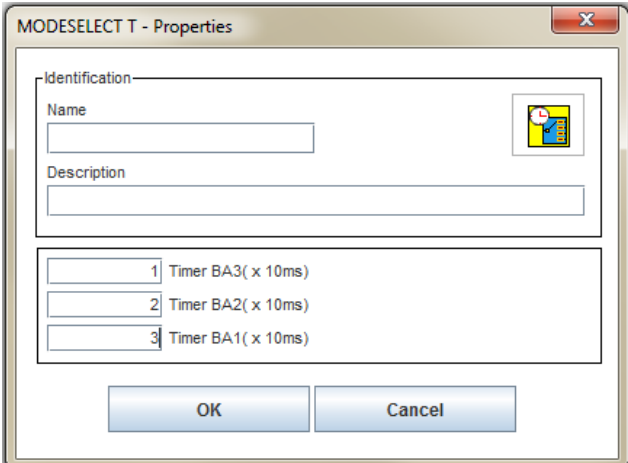
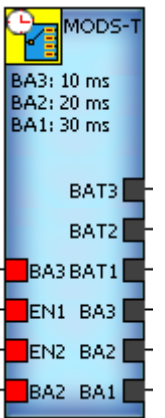
8.16. Operating mode selector T

Toolbar	Parameter field	Logic circuit symbol	description
			<p>MODS-T:</p>

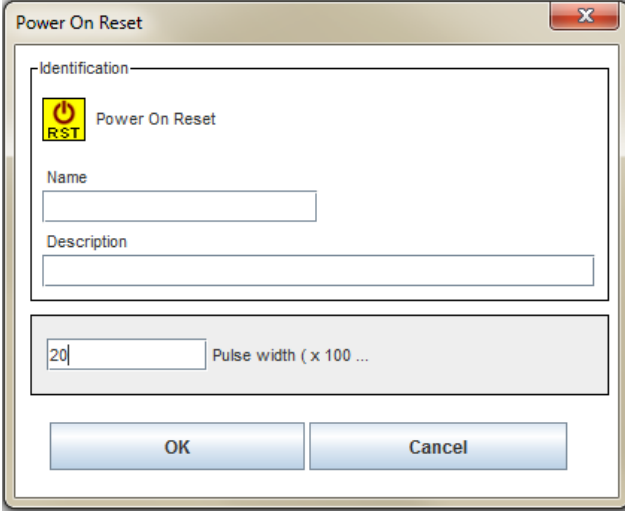
8.17. Power on Reset

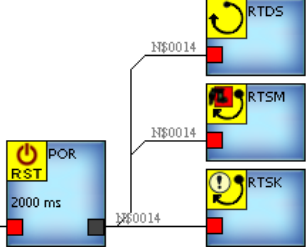
Toolbar	Parameter field	Logic circuit symbol	description
			<p>Power on Reset: This element can just be placed once.</p> <p>After Power on or after setting the input, the output is set to 1 for the duration of the parameterized time.</p> <p>The function can be used to set the enable signals. Example:</p> 

8.18. Analog-Error

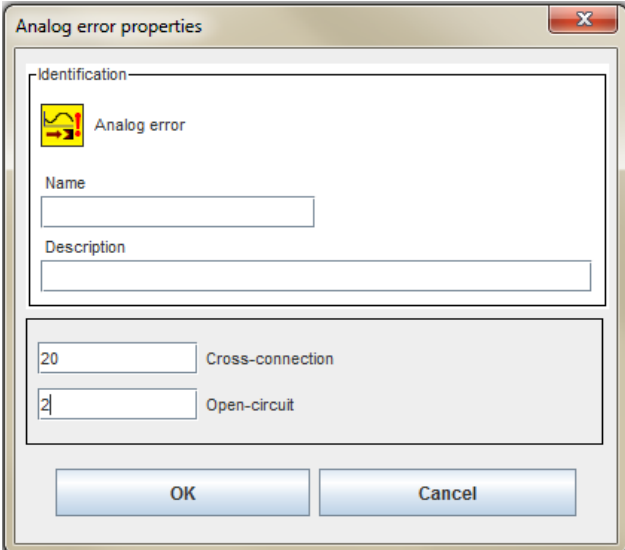
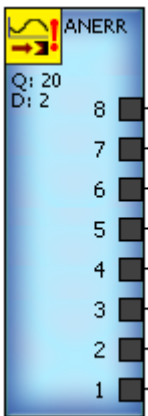
Toolbar	Parameter field	Logic circuit symbol	description
			<p>ANERR: This element can just be placed once.</p> <p>If there is a cross-connection or an open-circuit at an analog input, the correspondent output 1 ... 8 gets high.</p> <p>The monitored values have to entered in the fields.</p> <p>The following applies: The values to be entered: 0 ... 255 corresponding to a voltage range of 0 ... 24V.</p>

8.19. Conversion factor

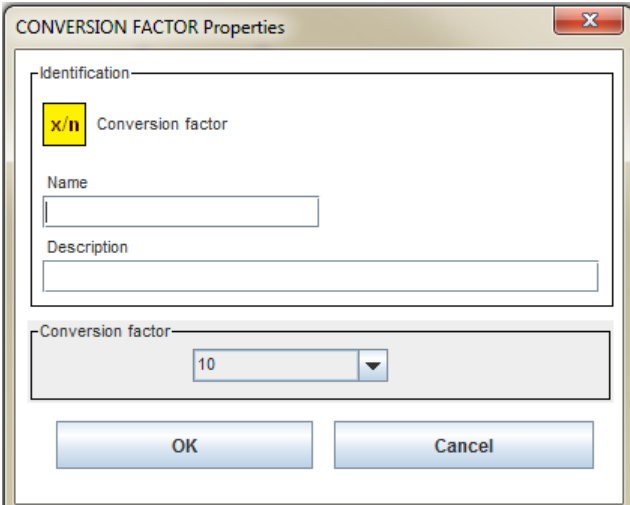
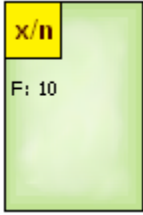
Toolbar	Parameter field	Logic circuit symbol	description
			<p>The element can only be placed once.</p> <p>About the Dropbox, a conversion factor can be selected. This appears in the icon.</p>

8.20. Adder

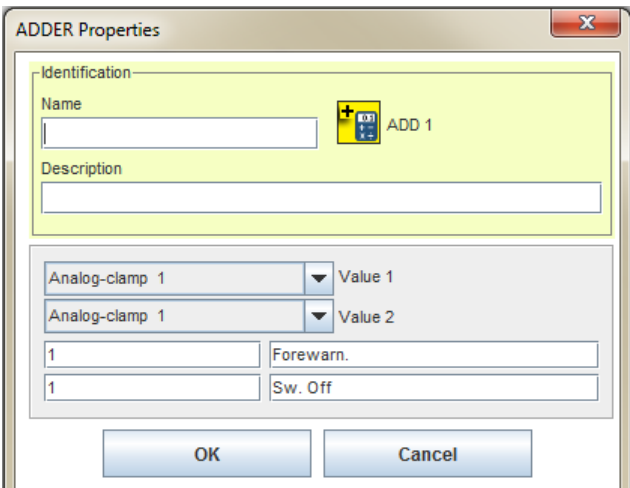
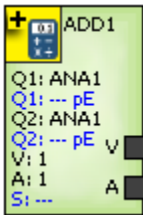
Toolbar	Parameter field	Logic circuit symbol	description
			<p>The adder adds the analog values 1 and 2.</p> <p>If the value is below the specified Sw.off value, the output A turns on. If he is over, the output turns off.</p> <p>The output V turns on if a given Forewarning limit is reached.</p>

8.21. Subtractor

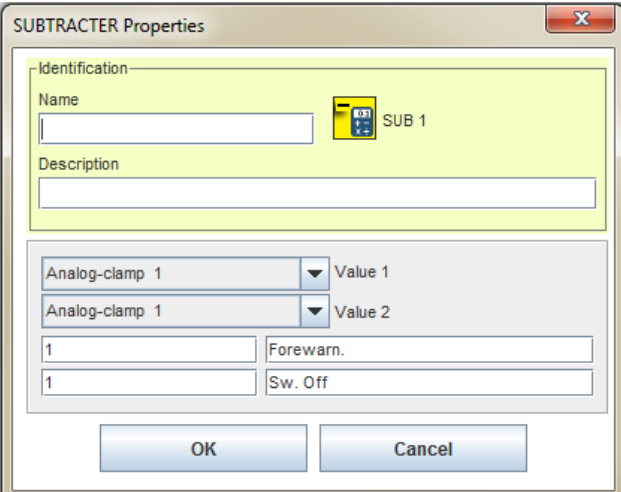
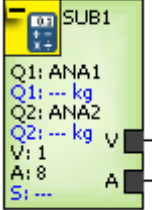
Toolbar	Parameter field	Logic circuit symbol	description
			<p>The subtractor subtracted the analog values 1 and 2. If the value is below the specified Sw.off value, the output A turns on. If he is over, the output turns off.</p> <p>The output V turns on if a given Forewarning limit is reached.</p>

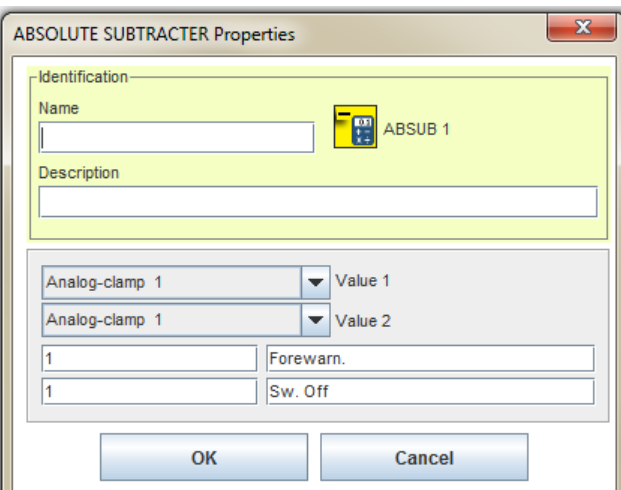
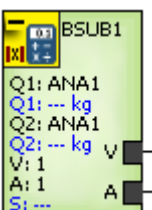

8.22. Absolute subtractor

Toolbar	Parameter field	Logic circuit symbol	description
			<p>The absolute subtractor subtracted the absolute analog values 1 and 2. If the value is below the specified Sw.off value, the output A turns on. If he is over, the output turns off.</p> <p>The output V turns on if a given Forewarning limit is reached.</p>

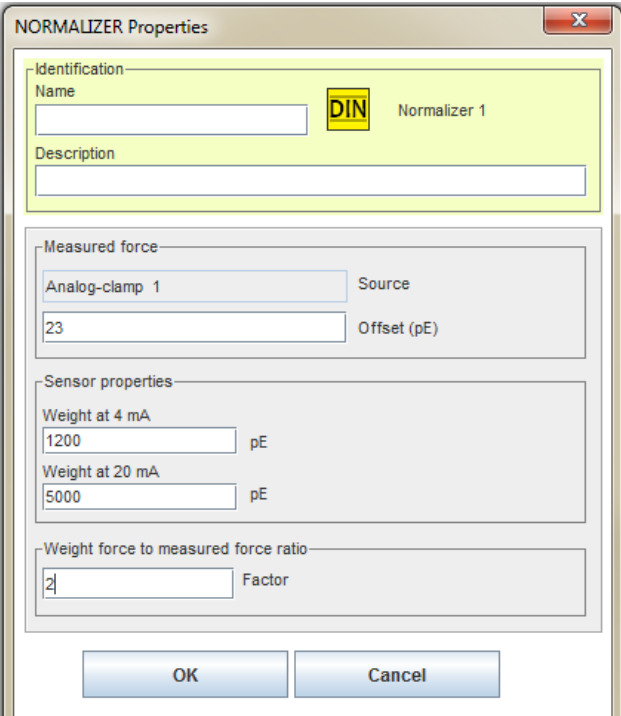
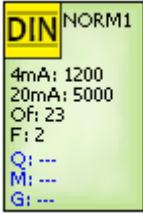
8.23. Normalizer

Toolbar	Parameter field	Logic circuit symbol	description
			<p>The selected analog terminal provides values between 4mA and 20mA. Each current value is assigned a weight.</p>

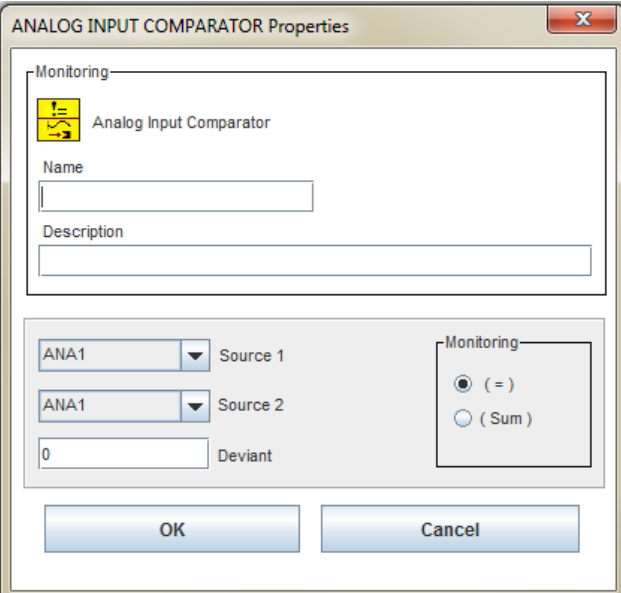
8.24. Analog Input Comparator

Toolbar	Parameter field	Logic circuit symbol	description
			<p>The AIC checks the input data of the source 1 and 2. In the pulldown menu, the sources can be selected. In addition, a tolerated deviation can be entered. The monitoring (=) switches the output (=), if both sources are equal within the deviation. The monitoring (Sum) switches the output (Σ), if the absolute sum of both sources, minus 100, is smaller than the set deviation.</p>

8.25. Threshold switch

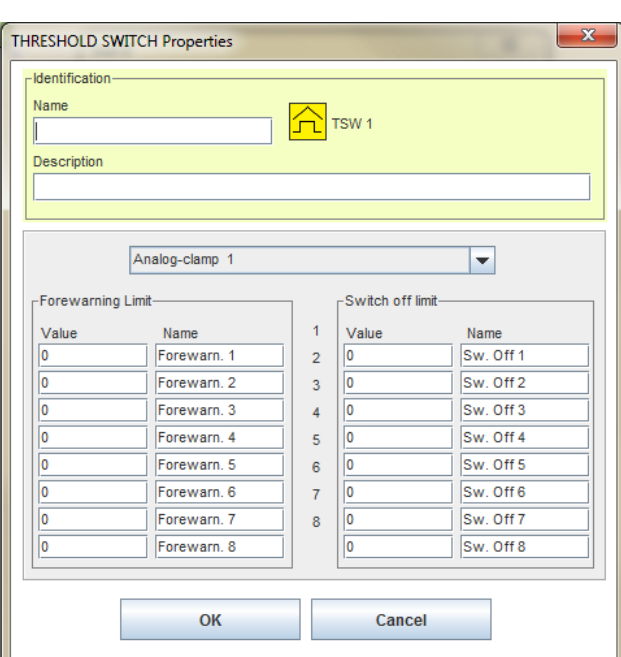
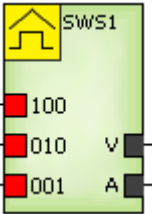
Toolbar	Parameter field	Logic circuit symbol	description
			<p>Each threshold can be configured with up to 8 different switching thresholds. At run time, one of these switching thresholds can be selected by a binary input signal patterns at each threshold. The outputs of the threshold respond to the currently set limits as a function of the selected source.</p>

8.26. Copier

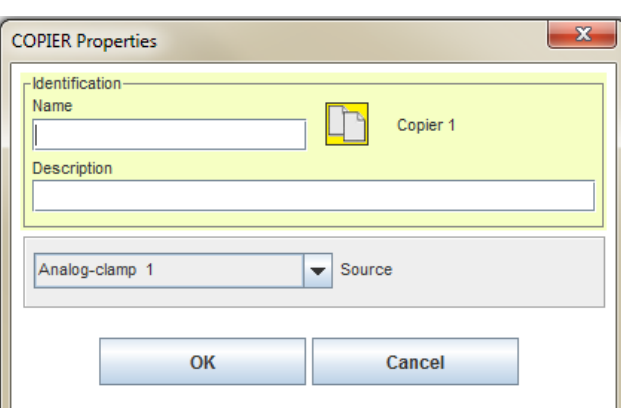
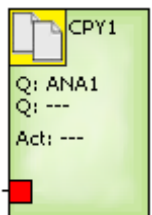
Toolbar	Parameter field	Logic circuit symbol	description
			<p>The copier stores, the source information, when the input signal is applied. The source can be an analog element. For input signal = OFF, the last stored value is retained.</p>

9. Inputs on the SLVario modules

Each SLVario module have a different number of inputs. Each input can be used as

- Digital, safety input (chapter 9.1.)
- Input of safety circuits (chapter 13) and
- Input of special safety function, e.g. analog input (chapter 9.4.)

9.1. Overview digital inputs

The following table shows SL VARIO modules with their available inputs (I) and in-/outputs (IO). These can be used for different safety relevant functions.

module	Inputs, In-/Outputs															
DNSL-ZMV	I1	I2	I3	I4	I5	I6	I7	I8	I9	I10	I11	I12	I13	I14	I15	I16
	IO1	IO2	IO3	IO4												
DNSL-DSV	I1	I2	I3	I4	I5	I6	I7	I8								
DNSL-DRV	I1	I2	I3	I4	I5	I6	I7	I8								
DNSL-INV	I1	I2	I3	I4	I5	I6	I7	I8	I9	I10	I11	I12				
	IO1	IO2	IO3	IO4												
DNSL-IOV	I1	I2	I3	I4	I5	I6	I7	I8								
DNSL-RMV	I1	I2	I3	I4	I5	I6	I7	I8								
DNSL-NIV	I1	I2	I3	I4	I5	I6	I7	I8								
DNSL-FBV	I1	I2	I3	I4	I5	I6	I7	I8								
DNSL-DPV	I1	I2	I3	I4	I5	I6	I7	I8								
DNSL-SIV	I1	I2	I3	I4	I5	I6	I7	I8								

9.2. Placement at the logic circuit

To place an element, the toolbar of the desired module have to be opened.

After selecting an input, the parameter field appears.

The toolbar icon, the parameter field and logic circuit symbol are identical over all inputs. The slot number of the selected input and the name (max. 8 char.) is shown in the parameter field.

The icon description can consist of 80 char. It is shown, if you lead the mouse over the symbol.

The clamp name can consist of 12 char. These appear in the yellow clam of the symbol.

Also you can select a debounce time of 4 or 16ms. These can be turned on or hidden in the symbol.



After clicking "OK", the symbol appears in the logic circuit and can now be placed.

Inputs that are already in use are identified in the toolbar with a "*" .

Toolbar	Parameter field	Logic circuit symbol	description
			<p>Digital input IN1</p> <p>Digital input IN1 Hidden is:</p> <ul style="list-style-type: none"> - description - debounce time - negated output

9.3. Configurable In-/Outputs

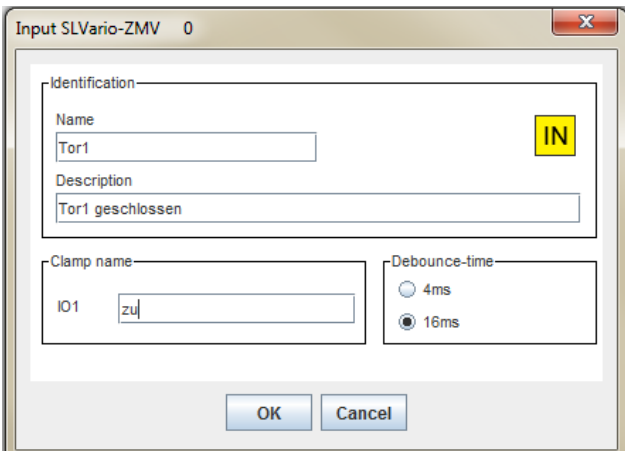
Some modules of SLVario include configurable in-/outputs, called IOs. That means, they can be used as digital inputs or as outputs. But these IOs can only be configured by pairs.

Toolbar	Parameter field	Logic circuit symbol	description
			<p>Digital Input IO1</p> <p>The IOs on ZM don't have negated outputs.</p>

 IOs can only be configured by pairs; e.g. IO1 and IO2 or IO3 and IO4 as input or output. (fig.1). Mixing, e.g. IO1 as input and IO2 as output, is not allowed and is blocked from the Designer.

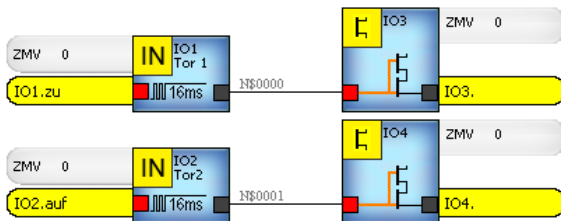



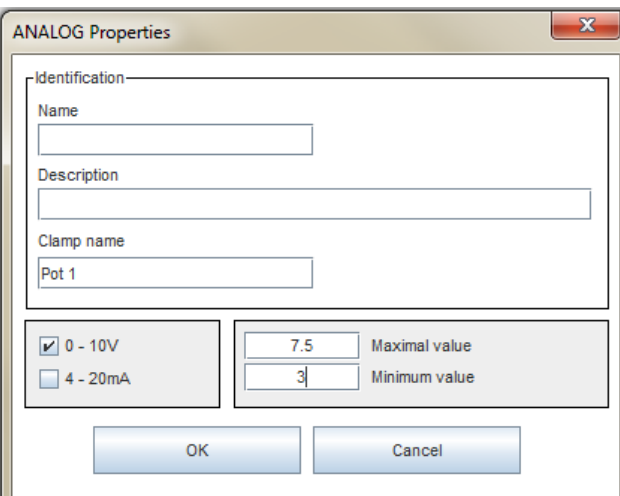

Fig. 1

9.4. Analog inputs

On the main module DNSL-ZMV and ZMVK the inputs I1 to I8 can be used as safety analog inputs. It is possible to interpret voltages from 0V up to 10V or to connect shut-down mats. At the inputs I1 to I4 you can also interpret current from 4 up to 20mA . Used analog inputs are no more provided as digital inputs.



Module	Analog input 0-10V							
DNSL-ZMV	I1	I2	I3	I4	I5	I6	I7	I8

Module	Analog input 4-20mA							
DNSL-ZMV	I1	I2	I3	I4				

Toolbar	Parameter field	Logic circuit symbol	description
	 <p>ANALOG Properties</p> <p>Identification</p> <p>Name</p> <p>Description</p> <p>Clamp name</p> <p>Pot 1</p> <p><input checked="" type="checkbox"/> 0 - 10V</p> <p><input type="checkbox"/> 4 - 20mA</p> <p>7.5 Maximal value</p> <p>3 Minimum value</p> <p>OK Cancel</p>	 <p>ZMV 0</p> <p>ANA1</p> <p>ANA1.Pot 1</p> <p>3-7.5V</p>	<p>Analog input ANA</p> <p>The output is high, if the voltage on I1 is between the min. and max. values.</p>

9.5. Analog Inputs for the safety-mat function

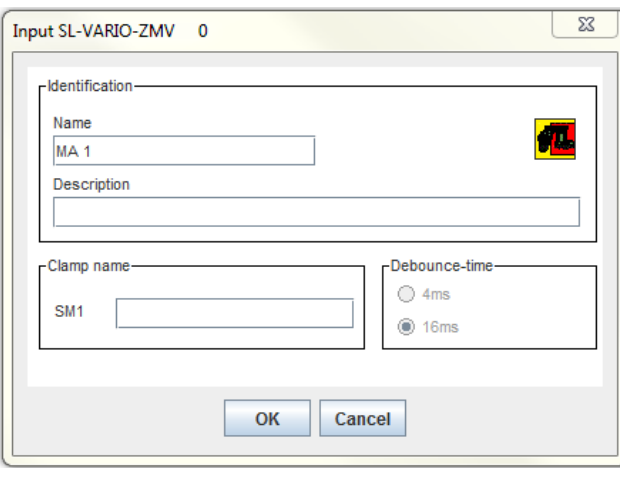
Up to eight shut-down mats can be connected to the input terminals I1 to I8.

Toolbar	Parameter field	Logic circuit symbol	description
	 <p>Input SL-VARIO-ZMV 0</p> <p>Identification</p> <p>Name</p> <p>MA 1</p> <p>Description</p> <p>Clamp name</p> <p>SM1</p> <p>Debounce-time</p> <p><input type="radio"/> 4ms</p> <p><input checked="" type="radio"/> 16ms</p> <p>OK Cancel</p>	 <p>ZMV 0</p> <p>SM1</p> <p>MA 1</p>	<p>Analog Input SM</p> <p>For every shut-down mat there is a virtual output. The corresponding virtual output has high signal, if the safety shut-down mat is not activated. Stepping on the safety shutdown mat or an internal malfunction of the mat will change the corresponding virtual output from high to low signal. The output changes again to high signal, if the mat is pressure free.</p>

9.6. Inputs for speed monitoring at the central module

The digital inputs I9 to I16 are provided to detect the drive speed using e.g. proximity switches or with a HTL incremental measuring system. More information you can find in chapter [Standstill- and motion monitoring with proximity switch on main module](#)

10. Outputs on the SLVario modules

The outputs can be used for safety relevant control functions as emergency stop, protection cover, permission, drives authorization, net authorization, to lock and unlock of protection cover and other safety functions.

The outputs can be also used for not safety relevant functions as valves, chip conveyor, cooling plant and other machine functions. SLVario has safety outputs, free configurable outputs and single outputs. There are semiconductor and contact outputs.

10.1. Overview of the outputs

The following outputs are available on the SLVario modules:
The fat printed outputs can be configured as clock outputs.

Module	Output/in-output					
DNSL-ZMV	O1	O2	O3	O4	O5	O6
	IO1	IO2	IO3	IO4		
	13/14	23/24				
DNSL-ZMV-KM	33/44	53/64	73/84	93/104		
DNSL-DSV	O1	O2	O3	O4	O5	O6
DNSL-DRV	O1	O2	O3	O4	O5	O6
DNSL-INV	IO1	IO2	IO3	IO4		
DNSL-IOV	O1	O2	O3	O4	O5	O6
DNSL-RMV	13/14	23/24	33/34	43/44		
DNSL-NIV	O1	O2	O3	O4		
DNSL-SIV	O1	O2	O3	O4		

10.2. Placement at the logic circuit

To place an element, the toolbar of the desired module have to be opened. After selecting an output, the parameter field appears.

Here you also can insert a name, description and clamp name.

The output can be configured as static, dynamical or clocked output.

After clicking "OK", the symbol appears in the logic circuit and can now be placed..



10.3. Configurable semiconductor outputs

The semiconductor outputs can be configured as

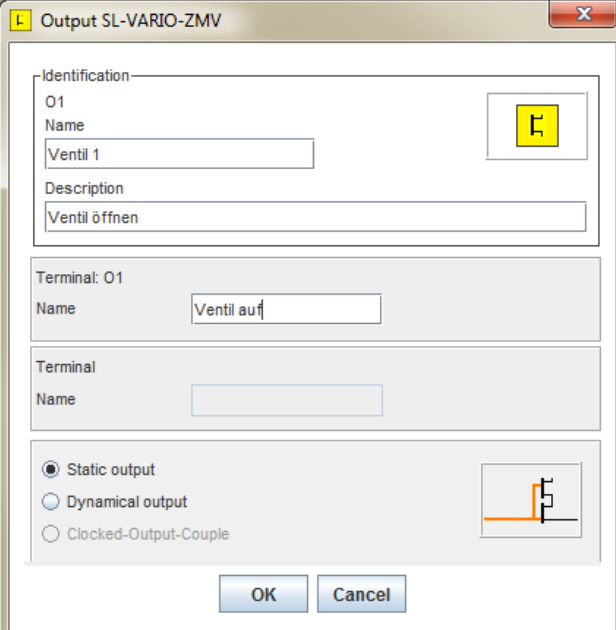

- Static output: safe output, switching positively
- Dynamical output: safe output, switching positively with test pulse (on ZMV only O1...O6)
- Clocked-output couple (see Overview of the outputs): Generate the clock for the dynamic activation of the safety circuits. The element has no input-pin in the logic circuit.

Placing and configuring are equal on all modules. The following symbols are representative for all modules.

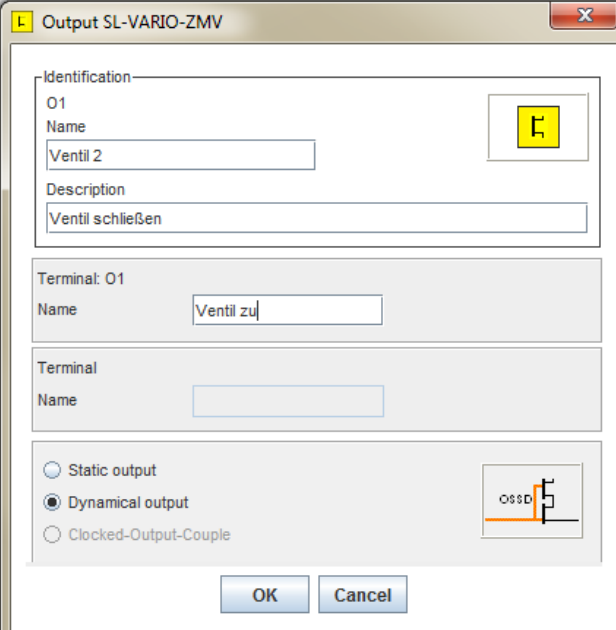
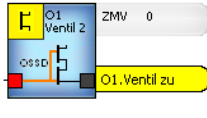

10.4. Static semiconductor output

Toolbar	Parameter field	Logic circuit symbol	description
			<p>Safe output, static Name and clamp name are shown in the symbol, the description is just shown, if the mouse leads over the symbol.</p>

10.5. Dynamical semiconductor output

Toolbar	Parameter field	Logic circuit symbol	description
			<p>Safe output, dynamical The configuration dynamical is shown in the symbol as OSSD</p> 

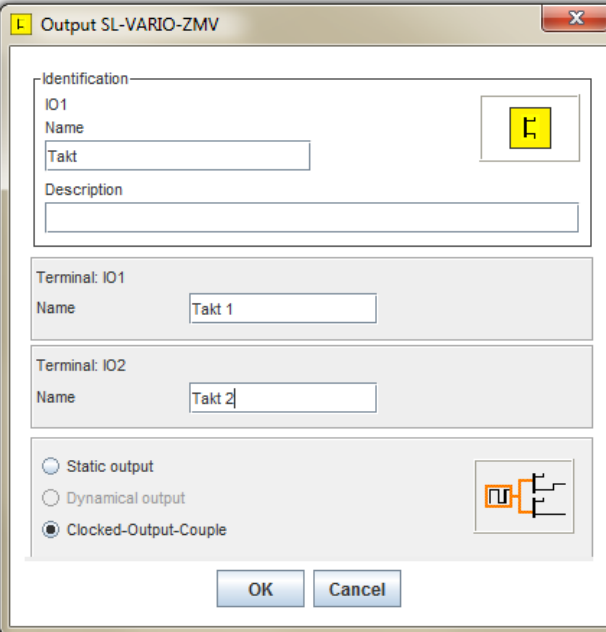
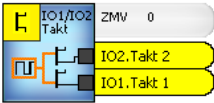
10.6. Clocked-output-couple

Toolbar	Parameter field	Logic circuit symbol	description
			<p>Clocked-output-couple The configuration clocked is shown in the symbol.</p> 

10.7. Safety contact (relay) outputs on DNSL-ZMV

2 relay outputs each one with safe NO contacts.

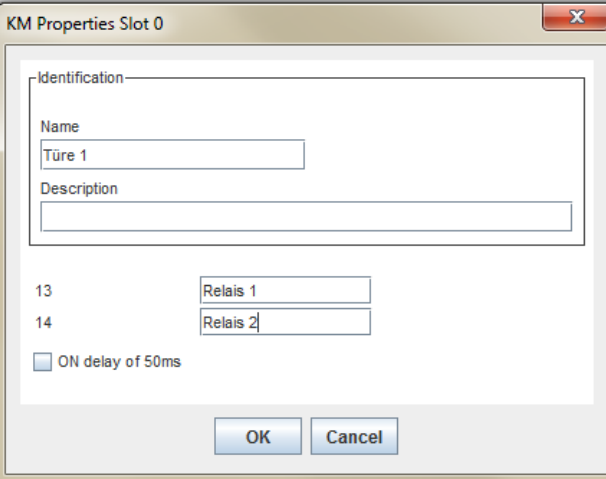
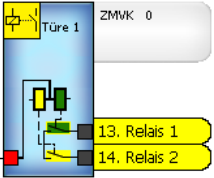
Toolbar	Parameter field	Logic circuit symbol	description
			<p>Output with a safe NO contact.</p> <p><i>ON delay of 50ms</i> This makes sense to avoid a conglutination on the relay contacts by large pull-in current. The relay contacts switch delay.</p>

10.8. Safety contact (relay) outputs on DNSL-ZMVK with output extension

4 relay outputs each one with 2 safe NO contacts.

Toolbar	Parameter field	Logic circuit symbol	description
			<p>Output with a 2 safe NO contacts</p> <p><i>ON delay of 50ms</i></p> <p>This makes sense to avoid a conglutination on the relay contacts by large pull-in current. The relay contacts switch delay.</p>

10.9. Analog Outputs on DNSL-ZMV/ZMVK



This feature requires a special hardware of ZMV/ZMVK.

The outputs O7 and O8 can be used as analog outputs. Depending on an analog input, the analog output gives voltage from 0 to 10 V. The assignment is via adjustable parameters.

Used analog outputs are no more available as switching outputs.

Modul	Analoge Ausgänge						
DNSL-ZMV/ZMVK	O7	O8					

Toolbar	Parameter field	Logic circuit symbol	description
			<p><i>Source:</i> Selection of the analog input .</p> <p><i>Min:</i> If this value is at source, the analog output has 0V.</p> <p><i>Max:</i> If this value is at source, the analog output has 10V.</p>

10.10. Safety contact (relay) outputs on DNSL-RMV

2 relay outputs each one with 2 safe NO contacts

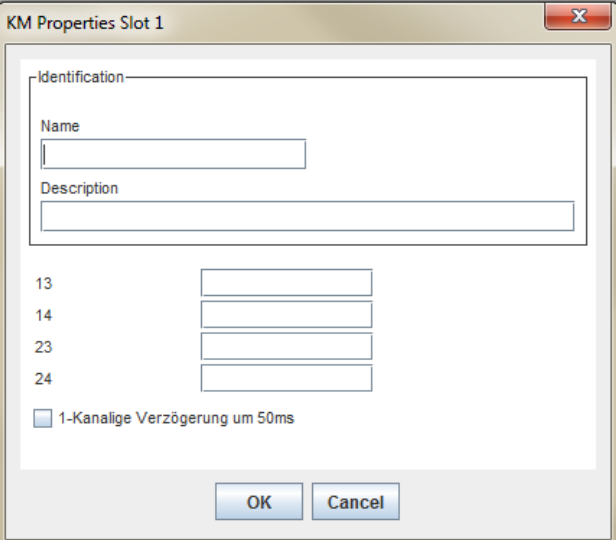
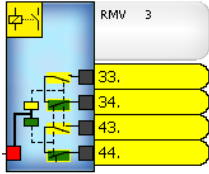
Toolbar	Parameter field	Logic circuit symbol	description
			<p>Output with two safe NO contacts.</p> <p><i>1-kanalige Verzögerung um 50ms</i></p> <p>This makes sense to avoid a conglutination on the relay contacts by large pull-in current. The relay contacts switch delay.</p>

11. Timer

Timer can be placed about the toolbar of the main module.
The timers are divided into ON-delayed and OFF-delayed timer.

11.1. Function description

The timers can be configured with a resolution of 10ms, in the range of 1 (-> 10ms) to 30000 (->300s).
With the inputs, different times can be realized. With a changing edge at the t/A1-input, the times for T, T1, T2 or T3 starts in dependence of the logic-level on the terminal t1, t2 and t3. The OFF-delayed timer expects a changing edge from HIGH to LOW, and the ON-delayed timer a changing edge from LOW to HIGH at the input t/A1.
If more than one input is HIGH, there is a prioritization of the times: $t_3 > t_2 > t_1 > t$
If, for example, during the edge on input t/A1 is changing its state while t1 and t3 is HIGH, then the time t3 based on. If t2 and t3 is LOW, then the time t is valid. Depending on the current state of the operation mode switch, different times can be chosen

11.2. OFF-delayed timer

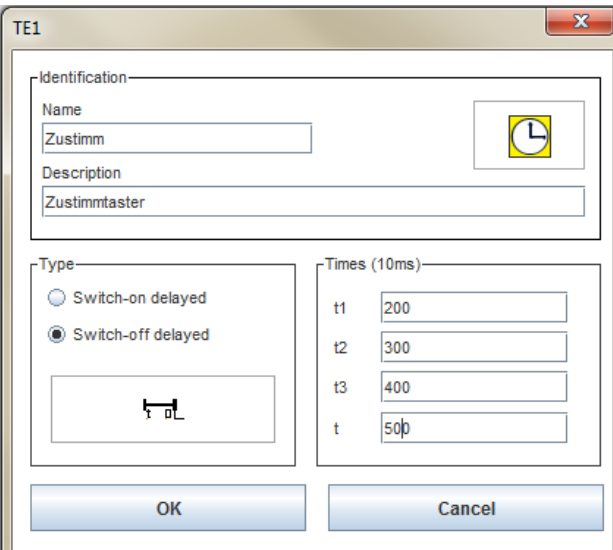
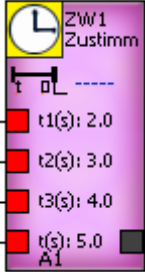
Toolbar	Parameter field	Logic circuit symbol	description
			<p>The output changes its state from HIGH to LOW after the time is expired.</p>

11.2. ON-delayed timer

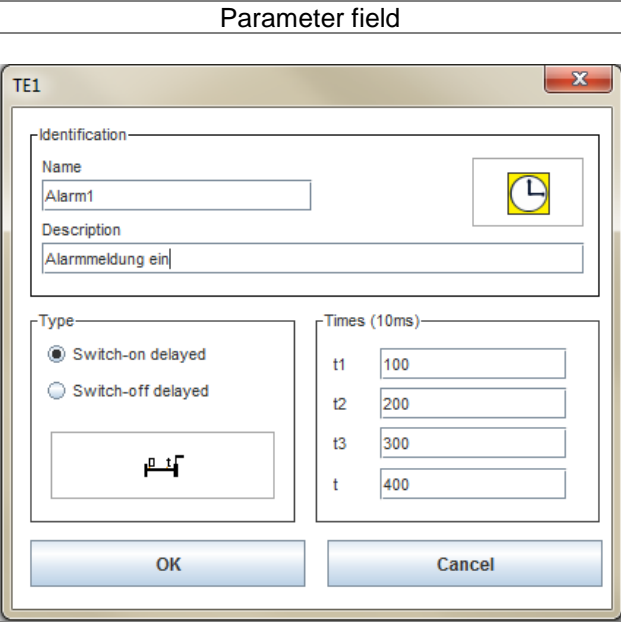
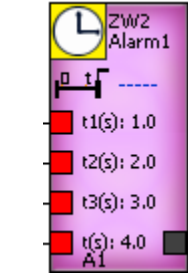
Toolbar	Parameter field	Logic circuit symbol	description
			<p>The output changes its state from LOW to HIGH after the time is expired.</p>

11.3. Example for an on-delayed timer

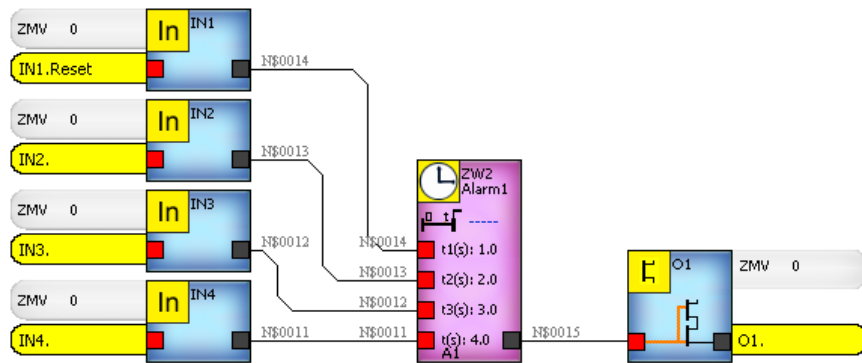

example

If IN1 is on and IN4 changes its state from low to high, the output O1 changes its state from LOW to HIGH after 1 sec.

 Wired inputs expect a time >0 sec.

12. Counter (in preparation)

Counter can be placed about the toolbar of the main module. The count value can be in the range of 1 to 30000. The counting direction is reversible about the circuit. The RESET input must be set before counting starts. The home position of the outputs is high. The output gets high-level, if the count value (up counter) reaches the configured count value or if the count value (down counter) reaches zero.

The up counter carries on with counting after switching off the output.

Toolbar	Parameter field	Logic circuit symbol	description
			<p>Reset: This input resets the count value. - Up counter: "0" - Down counter: count value</p> <p>Enable: High-Level: Counting process is released. Low-Level: Counting process is blocked.</p> <p>Up/Down: Counting direction High-Level: Up counter Low-Level: Down counter</p> <p>Clock: Input for counting pulses.</p> <p>Output: The output gets low-level, if the count value (up counter) reaches the configured count value or if the count value (down counter) reaches zero.</p> <p> Acquisition of the counting direction when the level at the enable input changes from low to high</p>

12.1. Example for a counter

IN3 defines the count direction „up-counter“. A unique pulse on the RESET input sets the count value on zero. (fig.1) IN2 releases counting.

The frequency synthesizer generates the clock. With each pulse, the count value will be increased. (fig.2). The output gets low-level, if the count value (up counter) reaches the configured count value. The counter carries on with counting as long as the ENABLE input is on. (fig.3)

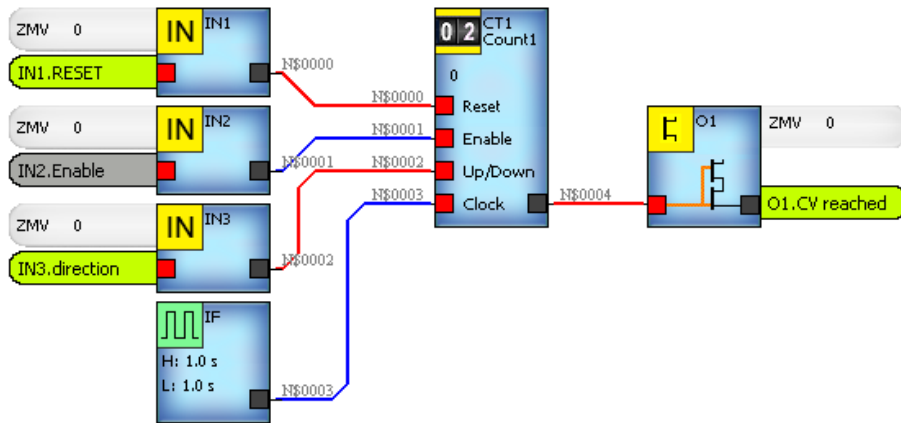

Fig. 1

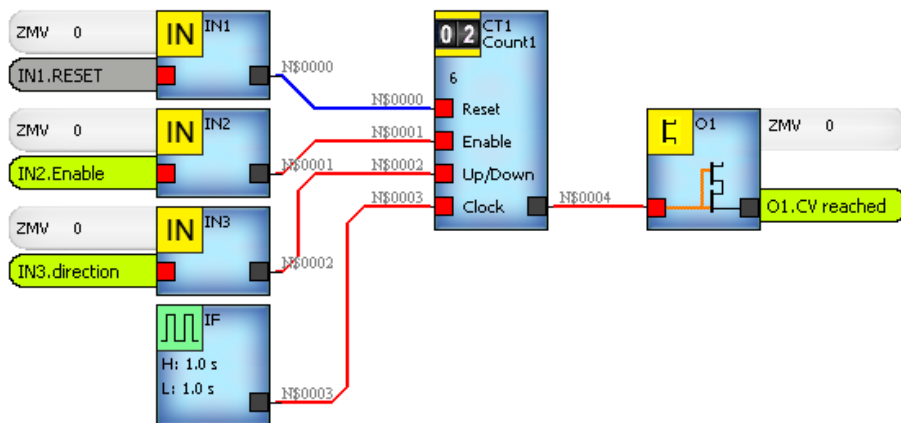

Fig. 2

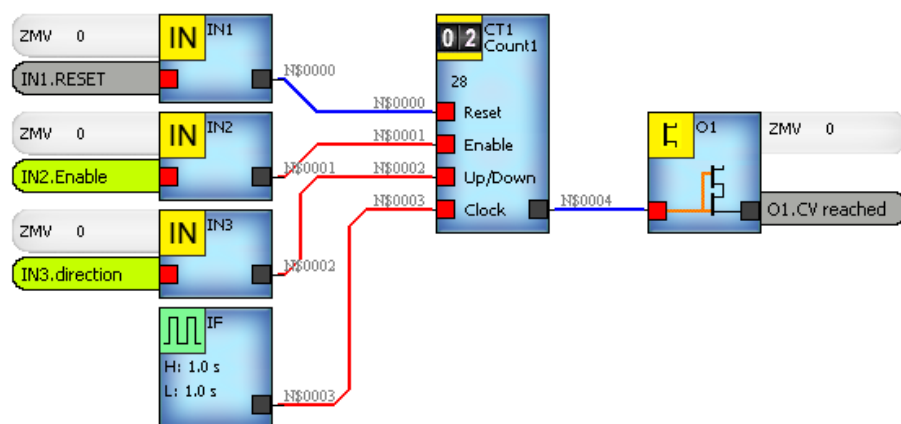



Fig. 3

13. Safety circuits

13.1. Digital inputs for the implementation of safety circuits

For realizing safety circuits, such as emergency stop, safety gate or light grid, specified digital inputs are available. An overview about the inputs and the possible number of safety circuits you can find in the instruction manual of SLVario over the HELP menu. The safety circuits can be configured variably. There are various kinds of activation and acknowledgements.

13.2. Configuration of the safety circuits

The toolbar of the desired module must be opened. After clicking on the arrow next to the icon , a list of remaining free safety circuits appear. After selecting the parameter field opens.

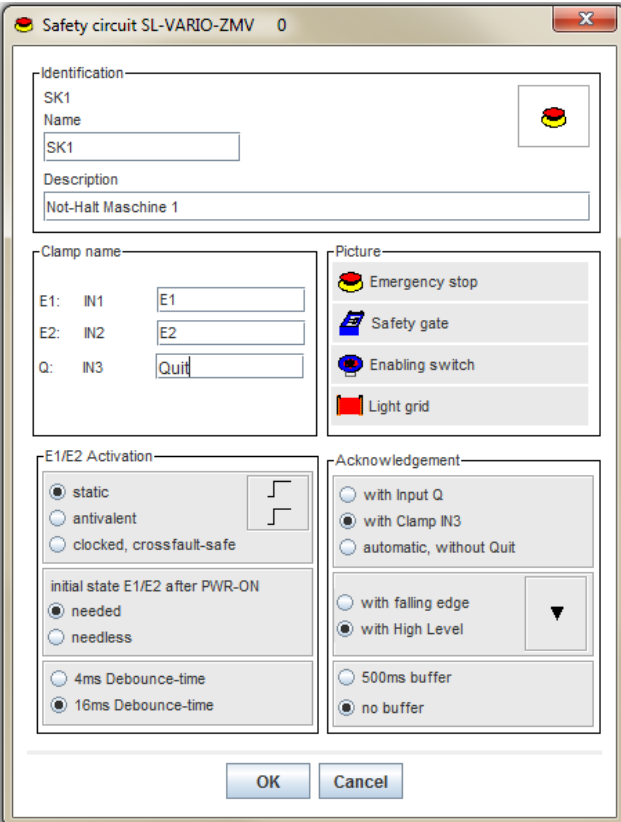
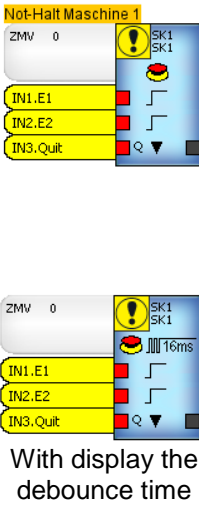
Toolbar	Parameter field	Logic circuit symbol	description
		 <p>With display the debounce time</p>	<p>Safety circuit SK1 with static activation and acknowledgement with clamp IN3. The output gets high level, if the conditions are complied. See Hardware Help</p>

Identification

Here you can describe the safety circuit with a name (max. 8 char.) and a description (max. 80 char.). If the element is set, the name appears in the symbol. The description is shown, if you lead the mouse over the symbol.

Clamp name

The clamp names can consist of 12 char. These appear in the yellow clam of the symbol.

Picture

According to the type, a symbol can be selected for emergency stop, safety gate, enabling switch or light grid.

E1/E2 Activation:

The activation of the safety circuit can be different:
static The control pulse E1 and E2 must be static.

antivalent The control pulse E1 and E2 must switch antivalent. The home position from E1 must be low and E2 must be high.

clocked The control pulse E1 and E2 must be clocked.. Clock outputs at SLVario have to be configured.

initial state E1/E2 after PWR-ON needed: After PWR-Off/On, the control pulses must be switched off and on to check the safety circuit.

needless: After PWR-Off/On, it is not required to switch off and on the control pulses.

Debounce-time Here you can select between 4ms or 16ms for E1, E2 and Q. For clocked safety circuits, only 16ms are possible.

Acknowledgement

with Input Q The quit signal is variable. Either it can be an input from another module or a virtual input.

with Clamp INx The quit signal is the next free input after the control pulse. Then the number of safety circuits decreases.

automatic, without Quit The safety circuit has no quit input. In this case the third input is available for other safety circuits or functions.

With falling edge with High Level The acknowledgement needs a falling edge.
The acknowledgement needs a high level.

500ms buffer The storage time for the quit signal is 500ms. The output gets high, if the activation is <500ms after the acknowledgment.

No buffer No storage of the quit signal.

Emergency stop requires a quit signal and the selection “no buffer”.

13.3. Logic circuit symbol of safety circuits

Below are some examples of safety circuits. The parameter fields are respectively the same for each safety circuit on each module. However, not possible configuration options are grayed out.

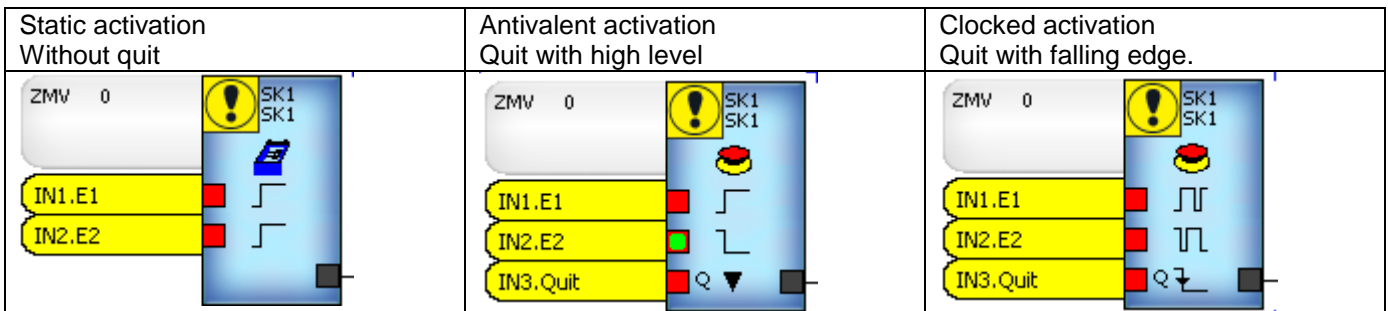

14. Two-hand-control

On each module, the realization of a two-hand control is possible through defined inputs. An overview of the inputs and the number of possible two-hand controls you can find in the hardware description in the help menu.

14.1. Configuration for two-hand-control

The toolbar of the desired module must be opened. After clicking on the arrow next to the icon , a list of remaining free two-hand-control appear. After selecting the parameter field opens.

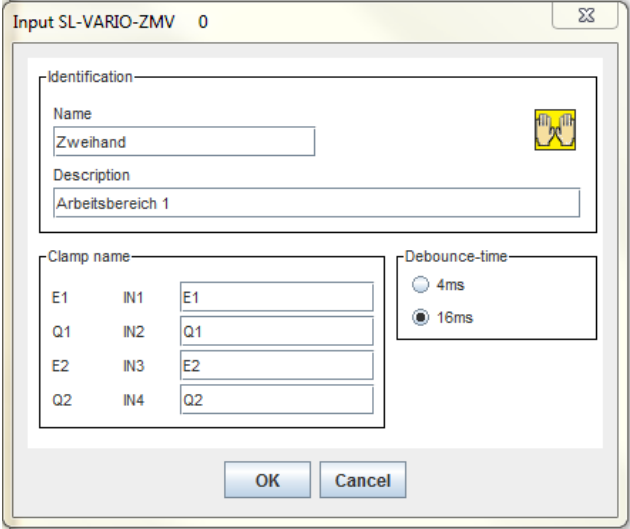
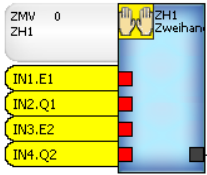
Toolbar	Parameter field	Logic circuit symbol	description
			<p>Two-hand-control The output switches when the conditions of activation are met. See Hardware Help</p>

Identification

Here you can describe the safety circuit with a name (max. 8 char.) and a description (max. 80 char.). If the element is set, the name appears in the symbol. The description is shown, if you lead the mouse over the symbol.

Clamp name

The clamp names can consist of 12 char. These appear in the yellow clam of the symbol.

Debounce-time

Here you can select between 4ms or 16ms for E1/E2 and Q1/Q2.

15.1 OF N

This logic determines from an 8-digit input signal pattern a 2-digit output signal pattern.

15.1. Configuration

The toolbar 2 of the central module must be opened. After clicking on the arrow next to the icon , a list of remaining elements appear. After selecting the parameter field opens.

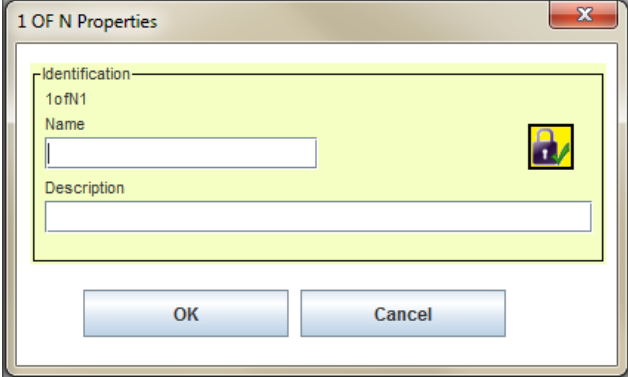
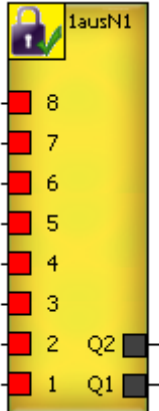
Toolbar	Parameter field	Logic circuit symbol	description
			<p>The output Q1 switches on, if one input is on and the other inputs are off, or if all inputs are off.</p> <p>The output Q2 switches on, if one input is off and the other inputs are on, or if all inputs are on.</p>

16. Freely configurable logic elements

Freely configurable logic elements are components, in which a custom logic can be implemented. 8 inputs and 8 outputs are available. Net lists can be reduced. The specific logic can currently only be implemented by DINA electronics.

16.1. Configuration

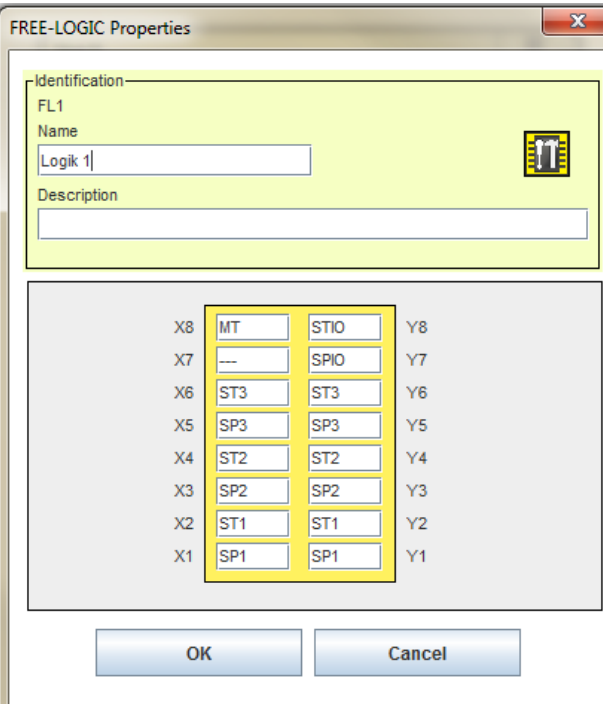
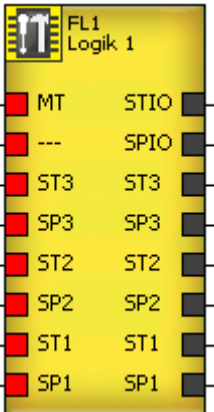
Toolbar	Parameter field	Logic circuit symbol	description
			<p>In this logic, a custom logic can be implemented by DINA. Please contact us.</p> <p>Possible logic elements are UND-, ODER- and XNOR Gates.</p> <p>The names of the inputs and outputs can be freely assigned.</p>

16.2. Summarized Motion monitoring for 3 drives

In the freely logic, it is possible to get summarized information about standstill and speed from 3 drives. Also you can get single information about each drive.

All drives can be simulated as safe standing with a MUTE signal.

This allows the creation of a maximum application in which non-existing drives do not affect the safety function

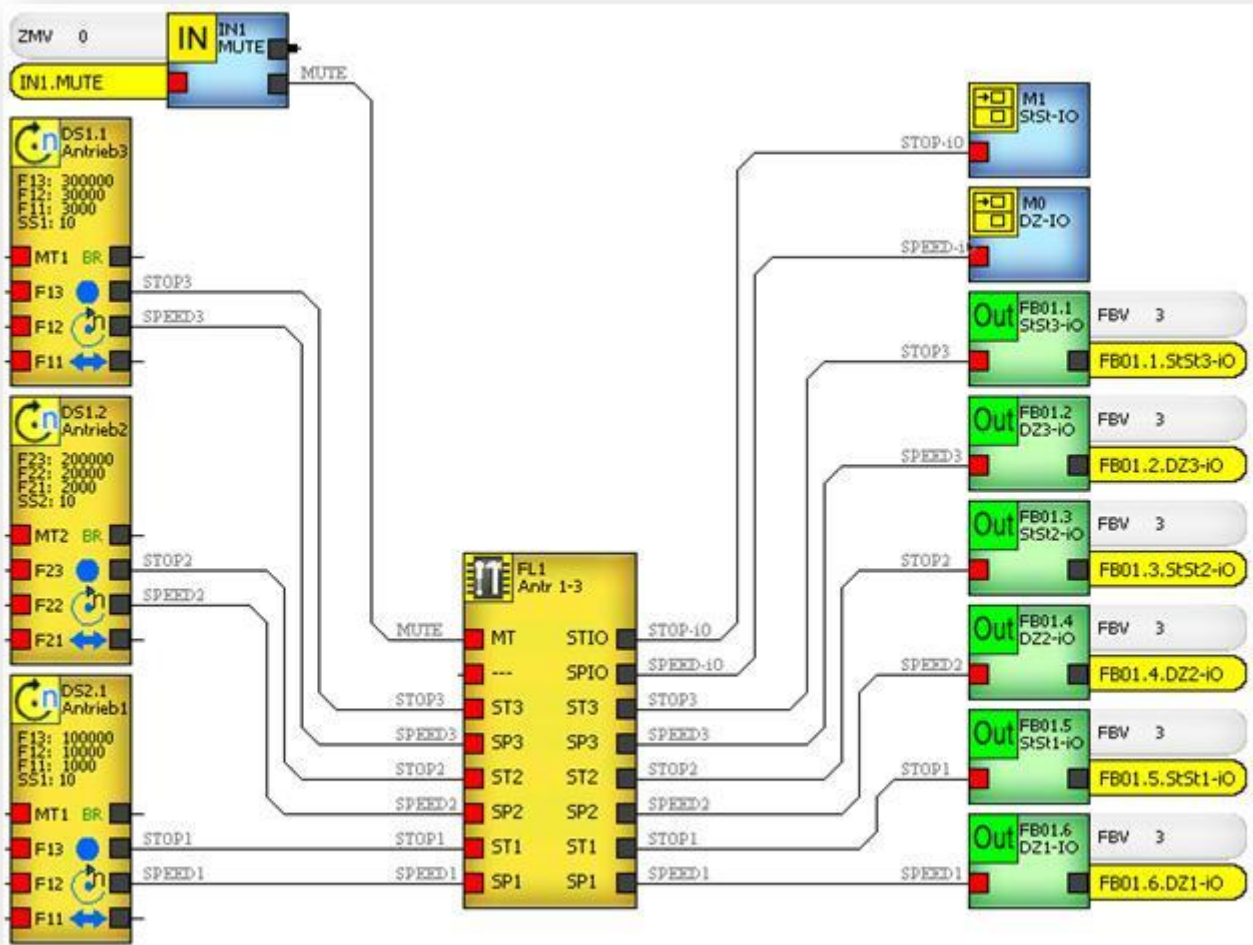

Inputs:

- MT: MUTE-input to simulate the safe state of all three drives
- ST3: Standstill (STOP) Drive3
- SP3: SPEED ok (SPEED) Drive3
- ST2: Standstill (STOP) Drive2
- SP2: SPEED ok (SPEED) Drive2
- ST1: Standstill (STOP) Drive1
- SP1: SPEED ok (SPEED) Drive1

Outputs:

- STIO: Standstill (STOP) of all drives
- SPIO: SPEED ok (SPEED) of all drives
- ST3: Standstill (STOP) Drive3
- SP3: SPEED ok (SPEED) Drive3
- ST2: Standstill (STOP) Drive2
- SP2: SPEED ok (SPEED) Drive2
- ST1: Standstill (STOP) Drive1
- SP1: SPEED ok (SPEED) Drive1

17. Guard door element

The guard door element realizes a logic control of a door opening (magnet) via a request- and an enable input (safety standstill) as well as an acknowledge input (after closing the door)

If the door has a warning light, the state of the door element can be visualized, using a frequency generator. Requirement=flashing; released= continuous light)

17.1. Configuration

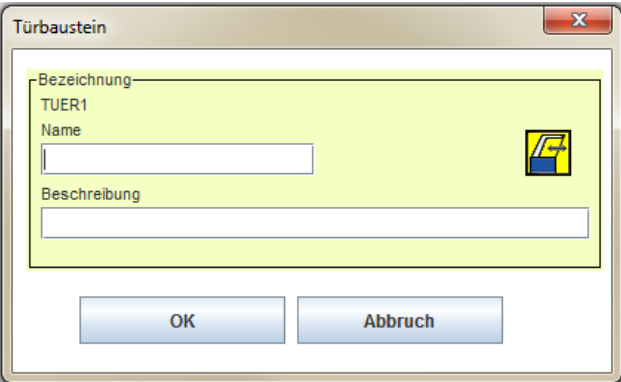
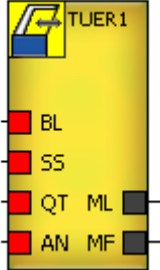
Toolbar	Parameter field	Logic circuit symbol	description
			<p>Inputs: BL for the frequency generator SS safety standstill QT quit AN requirement</p> <p>Outputs: ML warning light MF magnetic release</p>

18. Settings (Parameter – tables)

For all main module types and each function module is a parameter and connectors table available. By typing the key "T" or over menu Parameter Tables, the fields are open. On the left side the parameters from the desired module can be opened.

The parameter tables are divided in 3 areas:

- Configuration
- DNCO
- Cam



The field data are taken only with a click on the "OK" button. Press "Cancel", the entry is aborted.

18.1. Configuration main module

In the main module parameters, some important and relevant configurations can be done.

18.1.1. Parameter ZMV

Name

Here, a 12-digit name can be assigned.

Autostart:

If this function is activated, the SL-Vario is immediately ready for operation after transferring the application. Otherwise, the power supply has to switch off at least for 2s.

Verification:

If this function is activated, it will be checked if the whole application is transmitted correctly. The transmission time is extended.

Slok delay (s):

Time delay switch off (1 to 25s) of all outputs at SLVario after an internal or external error.

Muting (Muting of function modules)

This option is used for muting of function modules. The hardware inputs of the main module can be assigned to the function modules. If one of the inputs set to logic "1", the corresponding function module disappears.

If the function is not needed, then "---" must be selected.

SW

Software Muting is also possible.

For more information, see chapter [Muting](#)

Pos. Mon. Trip

With this function, a switch-off time <10ms can be achieved.

For this, the DSV module is in the menu "Fast shutdown from" selected, after which the function is active.

Then make the assignment of the outputs on the main module.

In the example, the outputs O3 and O5 would switch off quickly at overspeed on the DSV5.

The outputs O4 would switch off quickly at overspeed on the DSV6.

Other ways to speed up the shutdown see [Parameter of the motion monitoring](#)

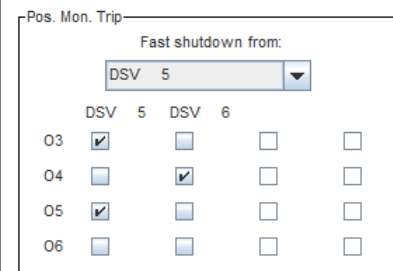
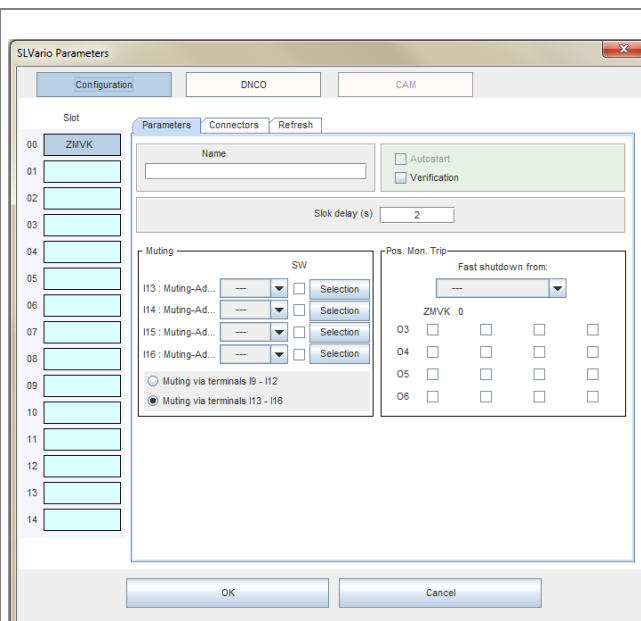

18.1.2. Connectors

In the area „connectors“, names (12 char.) for the various inputs and outputs can be assigned. The names will be taken over by a click on "OK". These are also visible in the element in the logic circuit.

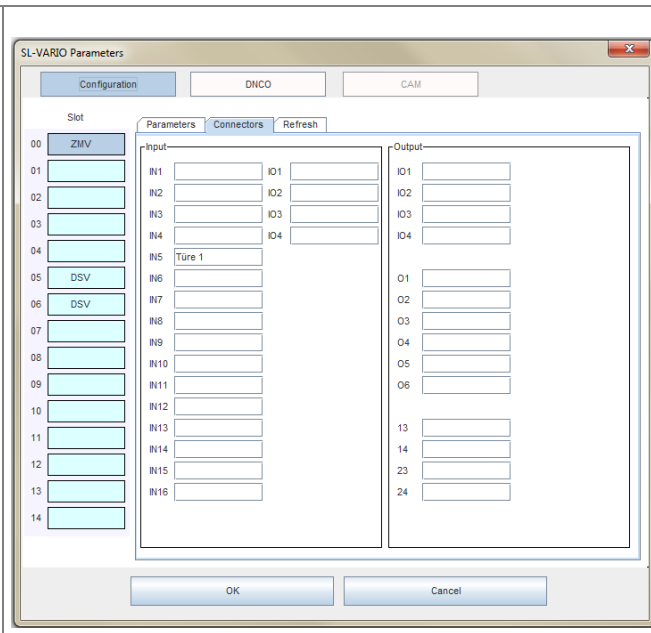

18.1.3. Refresh

In the "refresh" the refresh time for measured values, such as speed, position values are adjusted. By default 500ms are set. The adjustment range is between 10 and 500ms. By clicking on the arrow in the drop box you get a selection of possible refresh settings.

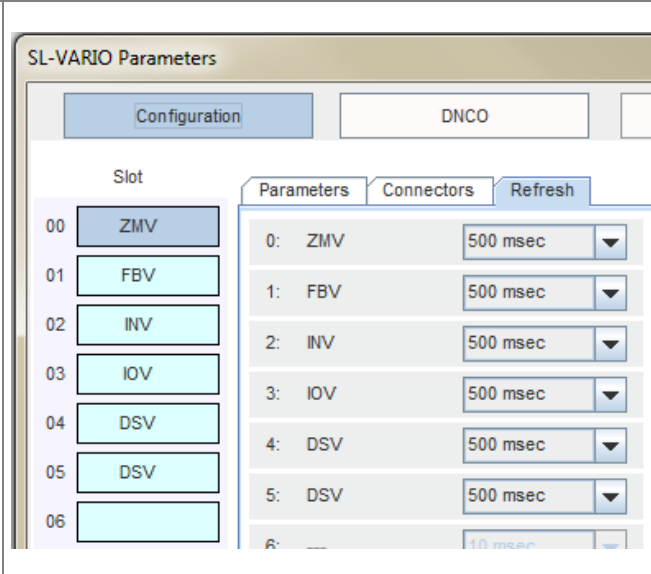

18.2. Parameter function modules

Only the function modules FBV, NIV, SIV and DSV / DRV have a special parameter range. These will be discussed in separate chapters. For the other function modules, the menu is limited to the connector names.

18.2.1. Connectors function modules

In the area „connectors“, names (12 char.) for the various inputs and outputs can be assigned. The names will be taken over by a click on "OK". These are also visible in the element in the logic circuit.

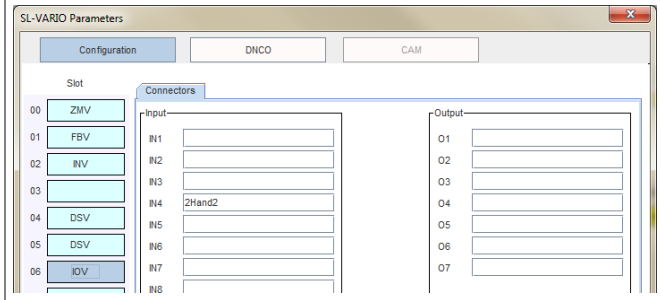
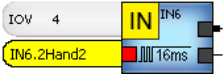

18.3. Parameter FB module FBV

Special settings for the fieldbus module FBV can be done via the menu parameter table settings.

Name:
Here, a 12-digit name can be assigned

Station address:
Field for station address in the range from 2 to 125.
Note: After a change of the station address the power supply of SLVario has to be switch off for at least 2s. Afterwards the new address is active.

Baud rate:
Setting the baud rate for CANopen bus by clicking on [?]

SLOK-Off if Fieldbus falls:
Switch off at central module, if there is an error at field bus

In case of FB faults the ZMV input bits are not cleared:
This feature must be selected when the input bits on ZMV should not be deleted when an FB error.

Number of FB-Octets
The number of needed octets can be automatically determined or fixed. The selection is made via the drop down menu.

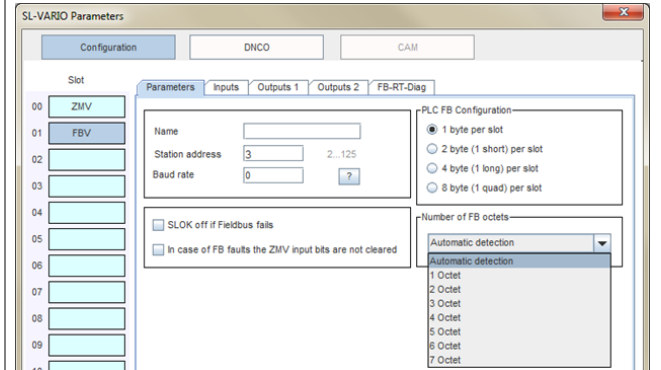

18.3.1. Connector names of the input/output of FBV

In the area „Inputs/outputs“ names (12 char.) for the various inputs and outputs can be assigned. The names will be taken over by a click on "OK". These are also visible in the element in the logic circuit.

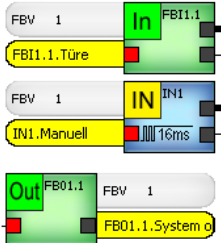

Using virtual Inputs and outputs for safety functions is not allowed.

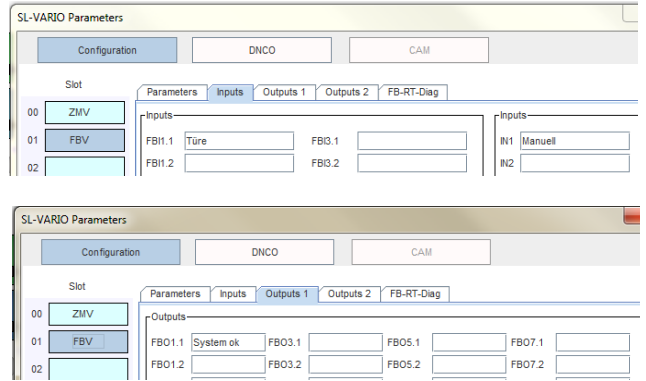

18.3.2. FB-RT-Diag

In the menu item FB RT-Diag is a comfortable Diagnosis available. By Drop down menus the states of various elements can be assigned to the FBV output bytes.

Slot

Selecting the module from which the data is to be diagnosed.

Element group

General selection of the element group.

Element

Special selection of the single element.

Length

Display of the actual data length of the selected element.

After selection the menu "Information" appears.

Accept setting

By selecting "Apply Setting" and the button "Apply" is defined, in which output the selected diagnostic data bytes are written. These are highlighted in yellow in the mask.

Reset setting

By Selecting "Reset Setting" and the button "Apply" the definitions will reset. „Ok“to accept the setting..

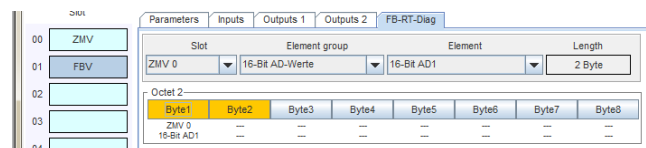
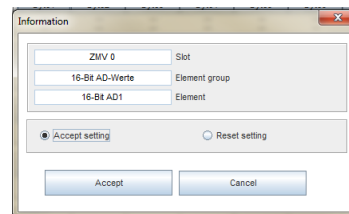
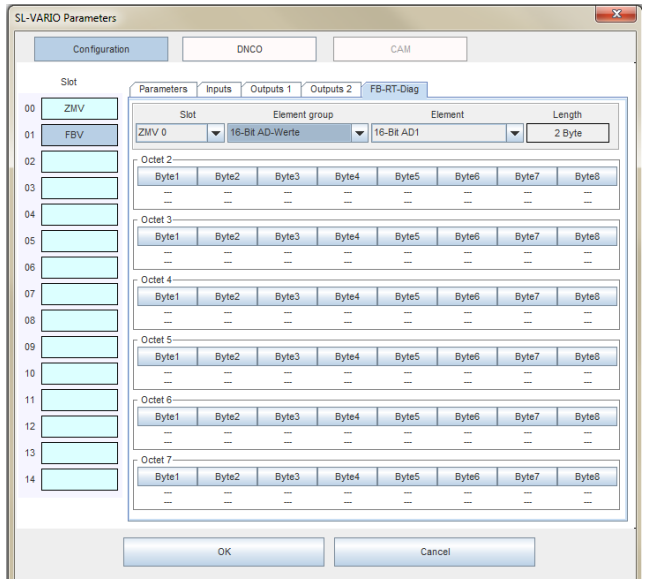

18.4. Parameter NIV-module (in preparation)

18.5. Parameter SIV-module (in preparation)

18.6. Parameter DSV/DRV-module

See chapter [motion monitoring](#).

18.7. DNCO

See chapter [DNCO](#)

18.8. Cam Parameter (in preparation)

19. Standstill and motion monitoring with proximity switch on main module

Motion monitoring in different function modes is possible on the main module.

The terminal digital inputs I9 to I16 are provided to detect the drive speed using e.g. proximity switches or a HTL measuring system.

The maximal frequency value at the terminal inputs is 1200Hz.

19.1. Inputs for motion monitoring on DNSL-ZMV

1st Choice: 4 one-channel standstill and speed monitoring and one safe

	DS1		DS2		DS3		DS4		DS6			
Meas.system	Sensor 1		Sensor 2		Sensor 3		Sensor 4		HTL			
									+A	-A	+B	-B
DNSL-ZMV	I9	I10	I11	I12	I13	I14	I15	I16				

2nd Choice: Two one-channel and two safe monitoring for standstill and speed

	DS1		DS3		DS4		DS6			
Meas.system	proximity switch 1		Sensor 3		Sensor 4		HTL			
	Sensor 1	Sensor 2					+A	-A	+B	-B
DNSL-ZMV	I9	I10	I11	I12	I13	I14	I15	I16		

3rd Choice: Three safe standstill and speed monitoring

	DS1		DS3		DS6			
Meas.system	proximity switch 1		proximity switch 2		HTL			
	Sensor 1	Sensor 2	Sensor 3	Sensor 4	+A	-A	+B	-B
DNSL-ZMV	I9	I10	I11	I12	I13	I14	I15	I16

4th Choice: Two safe monitoring, each with one incremental HTL measuring system

	DS5				DS6			
Meas.system	HTL				HTL			
	+A	-A	+B	-B	+A	-A	+B	-B
DNSL-ZMV	I9	I10	I11	I12	I13	I14	I15	I16

19.2. Proximity switch requirements

- 2 signals with 180° phase offset. One switch at the cog the another at the gap.
- • Positive switched to 24V DC (PNP)
- • The mounting has to enable at least one high signal at one input during the standstill.

19.3. Configuration for one-channel-monitoring

Toolbar	Parameter field	Logic circuit symbol	description
			<p>One-channel-monitoring via 1 sensor at I9.</p> <p>MT1 Mute F13 Automatic mode F12 Semiautomatic mode F11 tool setting mode</p>

19.4. Configuration for proximity switches

The selection for the safe monitoring via proximity switch takes place by the choice "two channels" in the parameter field:

I9 Sensor controlling disabled => on one-channel
 I9 + I10 Sensor controlling activ => on two channels, safe

Toolbar	Parameter field	Logic circuit symbol	description
			<p>Safe-monitoring via 2 sensors at I9 and I10.</p> <p>MT1 Mute F13 Automatic mode F12 Semiautomatic mode F11 tool setting mode</p> <p>Safe-monitoring via 2 sensors at I11 and I12</p> <p>MT1 Mute F13 Automatic mode F12 Semiautomatic mode F11 tool setting mode</p>

19.5. Configuration for a HTL-Measuring system

Toolbar	Parameter field	Logic circuit symbol	description
			Safe monitoring via a HTL Measuring system at I9, I10, I11, I12 MT1 Mute F13 Automatic mode F12 Semiautomatic mode F11 tool setting mode
			Safe monitoring via a HTL Measuring system at I13, I14, I15, I16 MT1 Mute F13 Automatic mode F12 Semiautomatic mode F11 tool setting mode

19.6. DZÜ (motion monitoring-) Parameter

The parameter field for motion monitoring is equal over the SLVario modules ZMV, DSV und DRV. Only by motion monitoring on the main module, not all functions are available. These are greyed in the parameter field
The exact description about all functions you can find in chapter [Configuration of motion monitoring](#)

19.7. Sens.monit. delay

Here, a delay time can be entered > 0 seconds within which a low level must be present on the sensor before the monitor turns off.

19.8. Features on one-channel-monitoring

19.8.1. DZÜ Parameter about fieldbus

The entry of the speed monitoring parameters can also be performed via the fieldbus:
Condition: Fx1 to Fx3 must be connected with 24V. MT can be selected as usual.
For each single-channel monitoring is in octet 2 to 5...

- set point 2 byte Hex
- Max. tool speed in U/min in 2 byte Hex
- Increments/rotation 1 byte Hex
- Tolerance on SS monitoring 1 byte
- Start ramp 1 byte hex
- Braking ramp 1 byte hex

Byte 1	Byte 2	Byte 3	Byte 4	Byte 5	Byte 6	Byte 7	Byte 8
Set point		Max. Tool speed in rot/min		INC/rotation	Tolerance	Start ramp	Br.ramp

20. Motion monitoring

20.1. General requirements to the measurement system (encoder)

With the function modules and DNSL-DSV and DNSL-DRV, it is possible to monitor two independent drive movements. An incremental measurement system (TTL or Sin/Cos) can be monitored with the DS-module, a resolver measurement system with the DR-module.

There are different cable adapters available with different plug connections to connect the monitoring with the feedback measurement system. RJ45 female plug is used at the monitoring. The configuration is done in the designer.

20.1.1. Incremental measurement system (TTL, HTL, Sin/Cos) with DNSL-DS



20.1.2. Resolver measurement system with DNSL-DR

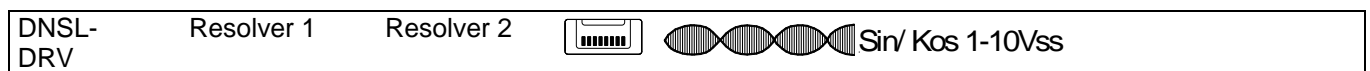

20.1.3. SSI interface measurement system with DNSL-SIV

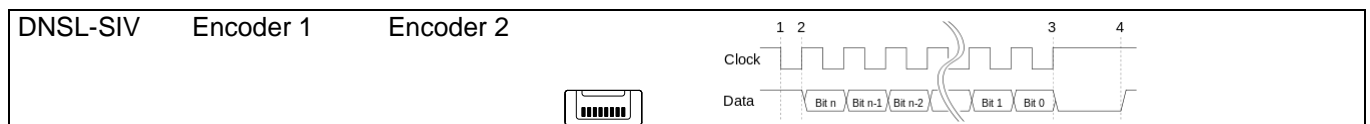

20.2. Configuration of motion monitoring

To configure the speed monitoring, the item must be selected and placed from the toolbar of the desired module.

After clicking on the arrow next to the icon , a list of remaining free monitoring appear. DS1 is the first and DS2 is the second. After selecting the parameter field opens. Then the following note appears.



Should no longer be displayed this regard, it can be selected here.

 A common mistake when creating an application is to forget to connect the restart (RTDS-) element.

The virtual input of the RTDS-Function  is used to quit the emergency stop status of a machine to avoid a restart.

A terminal input can be used to control the RTDS-function

In case of a continuous active RTDS an automatic restart is possible and must be prevented by other measures!

Now the module can be placed. The parameter can be called over the parameter tables or over the properties of the individual element.

Toolbar	Parameter field	Logic circuit symbol	description
			<p>Motion monitoring on DNSL-DSV</p>

20.3. Inputs of the motion monitoring

The control of the inputs can be done via hardware inputs and virtual outputs. There 4 operating modes can be selected:

MT1 (DS1) / MT2 (DS2): Inputs to mute the function mode. Only to use in particular situations. The virtual output is independent from this input.

F13 (DS1) / F23 (DS2): Input for the selection of the automatic mode

F12 (DS1) / F22 (DS2): Input for the selection of the semiautomatic mode

F11 (DS1) / F21 (DS2): Input for the selection of the tool setting mode

Priority of the virtual inputs at the monitoring DS1 and the monitoring DS2

$$MT1/ MT2 > F13/ F23 \quad || \quad F13/ F23 > F12/ F22 \quad || \quad F12/ F22 > F11/ F21 \quad || \quad F11/ F21 > \text{standstill}$$

20.4. Function of the virtual outputs of the rotation monitoring element

	<p>Virtual outputs of the brake monitoring. See chapter Brake monitoring with DNSL-DS Available only with DNSL-DS and DNSL-SIV.</p>
	<p>virtual output of standstill monitoring: high signal during $V_{actual} < V_{Standstill}$ and LOW signal during $V_{actual} > V_{Standstill}$ This output is independent of the selected function mode. Without measurement system has this output also high signal</p>
	<p>virtual output of V_{max}: HIGH signal at $V_{actual} < V_{max}$ and LOW signal at $V_{actual} > V_{max}$ The monitored speed is dependent of the selected function mode The output monitors the standstill, if no function mode is selected. HIGH at $V_{Actual} = V_{Standstill}$, LOW bei $V_{Actual} > V_{Standstill}$</p>
	<p>Virtual output of direction monitoring. See chapter Direction monitoring with DNSL-DS, DR Available only with DNSL-DSV/DRV and DNSL-SIV</p>

If the output is turned off by over speed or improper measuring system, it can be switched on again after a reset via RTDS .

20.5. Parameter of the motion monitoring

DZÜ DS1

Selection of the first motion monitoring.

DZÜ DS2

Selection of the second motion monitoring.

Connectors

Selection of the connector tables

Info1**Name**

Field to enter the name of the monitored axis (8 char.).

Description

12 characters are possible.

Info2**Adapter**

Type of the used DINA cable adapter.

Interface

Description of the encoder Interface.

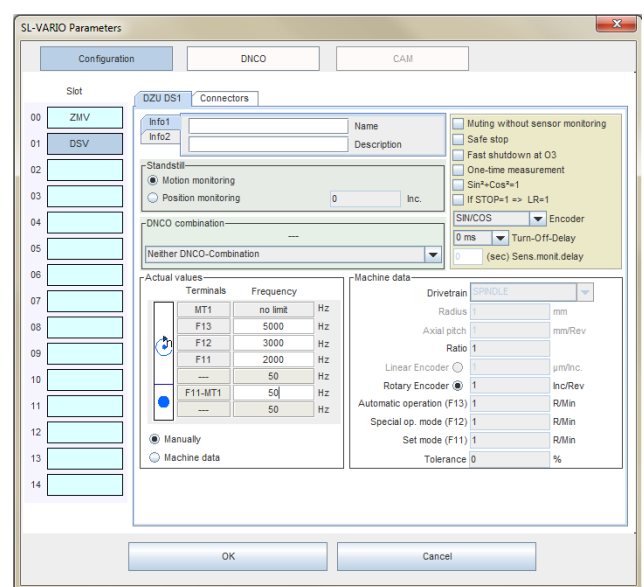
**Muting without sensor monitoring**

This option is used to mute the encoder input when no sensor is connected. Monitoring is hidden when the MT input is set. The virtual outputs for standstill and speed monitoring of the DS elements are set to logic "1". If this option is not selected, no sensor is connected and the MUTE input is set, then the output speed monitoring is set to logic "0". The output standstill remains on logic "1".

Safe stop

If this option is selected and no sensor is connected, the output standstill and speed monitoring is set to logic „0“.

Otherwise the output speed monitoring is set to logic „0“. The output standstill remains on logic „1“.

Fast shutdown at O3 on DS1 or O4 on DS2

When selecting this function, the output O3 (DS1) or O4 (DS2) of the DSV are used for fast shutdown in case of overspeed.

Shutdown times < 8ms can be reached.

In the application, the output speed monitoring must wired to the corresponding output.

One-time measurement

Shutdown times < 4ms can be reached.

 $\sin^2 + \cos^2 = 1$

Monitoring the signal amplitude. (Can at high frequencies may lead to intermittent faults!)

If STOP=1 => LR=1

If this function is selected, the output direction monitoring has high signal, as well as the output standstill monitoring high signal has.

Encoder

Type of measurement signals.

Turn-Off-delay

Here you can enter a time from 0 ms to 750 ms during which turns off the monitor after detecting an overspeed. Not available, if Position monitoring is selected.

Sens.monit.delay

Only by monitoring with proximity switches on ZMV.

Standstill

Here you can switch between "Speed monitoring" and "Position monitoring". After activation "Position monitoring" the number of allowable increments can be entered. Within this range, the axis can move left and right, without a shutdown.

DNCO-combination

Select a DNCO function. See chapter [DNCO Function on DNSL-DS/DR](#)

Actual values

The frequency values are the values of the measurement system for the corresponding monitored speeds. 4 frequencies have to be entered in the fields F11-MT1, F11/F21, F12/F22 und F13/F23.

1. Standstill frequency: The absolute standstill cannot be monitored because of the function safety. Therefore a low frequency has to be entered. Empirically the standstill frequency has to be 5 to 10% of the tool setting speed frequency. The monitoring of the standstill is active, if no function mode is selected. F11/F21 to F13/F23 and MT1/MT2 has low signals. A hardware output can be controlled using the virtual standstill output to lock and unlock a machine protection cover. The standstill frequency is also the monitored frequency for the virtual output, if no function mode is selected. F11/F21 to F13/F23 and MT1/MT2 has low signals. The system deposit the standstill frequency automatic in the field beyond. Instead of a frequency monitoring the position of an axis can be monitored.
2. Tool setting mode frequency: This function mode can be selected using the virtual inputs F11/F21. F12/F22, F13/F23.
3. Semiautomatic mode: This function mode can be selected using the virtual inputs F12/F22. F13/F23 and
4. Automatic mode: This function mode can be selected using the virtual inputs F13/F23.
5. Not monitored automatic mode: This special function mode can be selected using the virtual inputs MT1/MT2. No frequency value has to be entered..

Machine data:

When selecting machine data, the frequency values are calculated automatically based on machine-specific data. After selecting the type of the mechanical axis, values are entered into the table.. After entering the speeds to be monitored and possibly a tolerance value, the corresponding frequency value is automatically calculated and entered in the list of the current values. This is a sanity check. If the frequency value is out of range, the respective field is red. Only when all the values are within the permissible range, they can be taken with OK. If „Manually“ is selected, this frequency data is overwritten with the data previously entered manually. With repeated selection of the machine data, the calculated data are entered again.

Machine data

Drivetrain	SPINDLE	
Radius	1	mm
Axial pitch	1	mm/Rev
Ratio	1	
Linear Encoder	<input type="radio"/>	1 μm/Inc.
Rotary Encoder	<input checked="" type="radio"/>	1024 Inc/Rev
Automatic operation (F13)	5000	R/Min
Special op. mode (F12)	3000	R/Min
Set mode (F11)	2000	R/Min
Tolerance	2	%

Actual values		Machine data	
Terminals	Frequency		
MT1	no limit	Drivetrain	SPINDLE
F13	2001920	Radius	1 mm
F12	52224	Axial pitch	1 mm/Rev
F11	34816	Ratio	1
---	1	Linear Encoder	<input type="radio"/> 1 μm/Inc.
F11-MT1	1	Rotary Encoder	<input checked="" type="radio"/> 1024 Inc/Rev
---	1	Automatic operation (F13)	115000 R/Min
		Special op. mode (F12)	3000 R/Min
		Set mode (F11)	2000 R/Min
		Tolerance	2 %

Manually
 Machine data

OK Cancel

21. Position monitoring

The position monitoring is used for monitoring of an axis or spindle to a defined area.

This area is determined by the number of permitted increments.

The position monitoring select as follows:

1. Go to the menu of the Encoder input (Here e.g. DNSL DSV Encoder DZÜ DS1)
2. After clicking the button „Position monitoring“ the number of allowable increments can be entered. Within this range, the axis can move left and right, without a shutdown.

This value is taken in the table „Actual values“ and defines the shut down for the and speed output on the DSV-element, if no function mode is selected (F11-F13, MT1 low).

With the usage of DNSL-DR (Resolver measurement system) the entry is “1” for both monitoring.

With using single-pole resolver the possible movement window is ca. angle 10°.

With using multipolar resolver is the possible movement window accordant smaller.

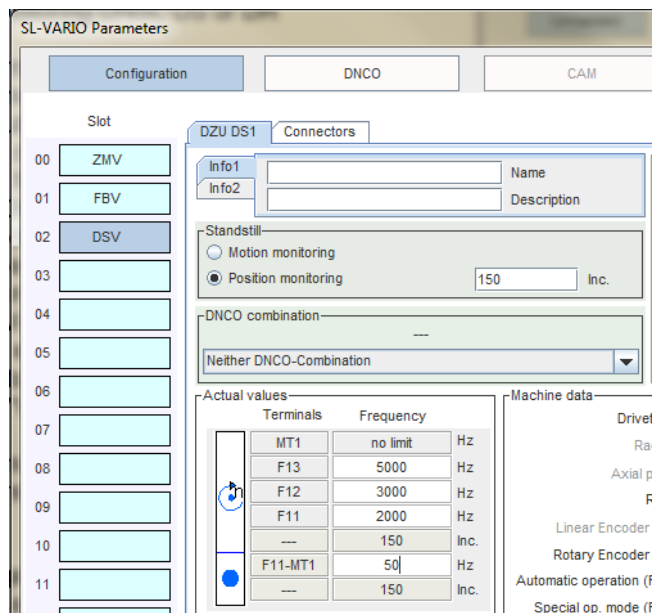

22. Direction monitoring with DNSL-DS, DR

During standstill and as long as the sinus is advanced, the virtual output has high signal and low signal, if there is an advanced cosinus. The direction can be detected about logic operations with the standstill output.

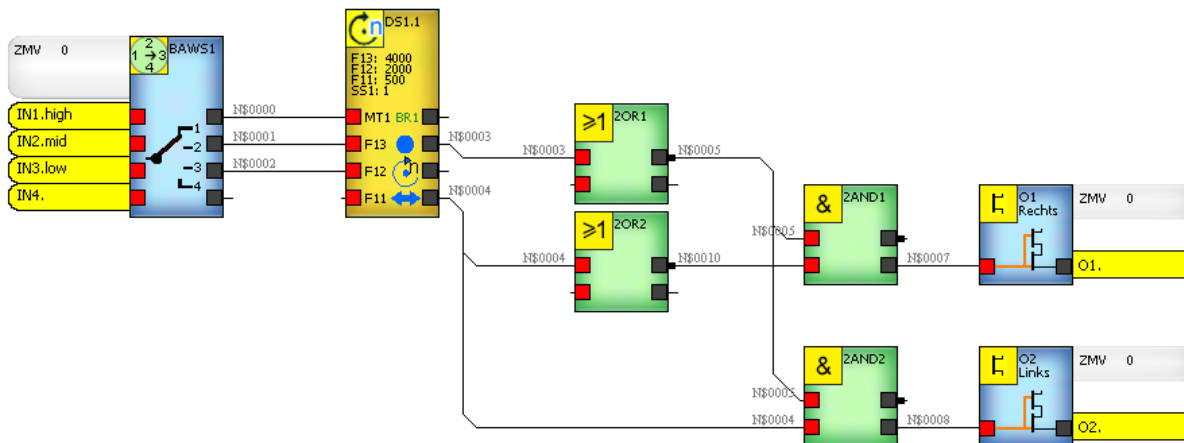

23. Brake monitoring with DNSL-DS

The virtual output **BR** can be used to monitor the brake function of a drive. The speed of the drives will be recorded every 100ms during a time of 500ms. After this time the first value will be overwritten.

During standstill, constant speed and acceleration the virtual outputs have low signals. They change to high signals, if the speed is reduced at least of 5% during a time of 500ms.

The shortest reaction time is 100ms.

Hardware outputs can be triggered with these virtual outputs.

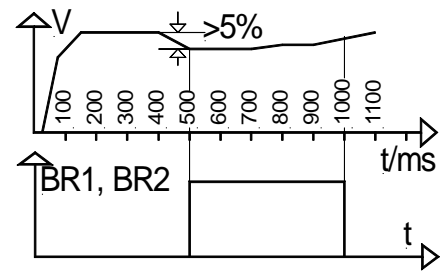

24. DNCO-Function on DNSL-DS/DR

The DNCO function allows the speed control of

- Up to 16 different speeds for each encoder and function mode.
- Or
- Up to 64 different speeds for each encoder in the automatic mode.

The speeds can be entered into two frequency tables on the main module.

Each encoder may be monitored for these values. The assignment which encoder on which table is accessing is done in the parameter mask of the DSV. The selection of frequencies can be realized by the bit coded wiring of inputs on the main module or the function modules. There are 3, 4 or 6 inputs provided for it.. With 4 inputs, the frequencies for all modes can be selected. If more than 16 frequencies required, 6 inputs are provided for this. Then the DNCO function can however only be used in the automatic mode.

Alternatively, the selection of the frequencies in all modes can be done via any inputs. In this case, the logic module "DNCO multiplexer" must be placed in the application. See [DNCO Function with Multiplexer](#)

24.1. Digital inputs for DNCO function

	DZÜ at Encoder 1				DZÜ at Encoder 2			
DNSL-ZMV	I1	I2	I3	I4	I5	I6	I7	I8
DNSL-DSV	I1	I2	I3	I4	I5	I6	I7	I8
DNSL-DRV	I1	I2	I3	I4	I5	I6	I7	I8
DNSL-INV	I1	I2	I3	I4	I5	I6	I7	I8
DNSL-IOV	I1	I2	I3	I4	I5	I6	I7	I8
DNSL-NIV	I1	I2	I3	I4	I5	I6	I7	I8
DNSL-SIV	I1	I2	I3	I4	I5	I6	I7	I8
DNSL-RMV	I1	I2	I3	I4	I5	I6	I7	I8
DNSL-FBV	I1	I2	I3	I4	I5	I6	I7	I8

24.2. Selection of the DNCO Function

The selection of the DNCO function takes place in the parameter field of the speed monitoring of the DSV / DRV module. First the element must be placed on the logic circuit.

At the area DNCO-combination, six functions are available. The selected combination is shown in the overlying window

The inputs used to it will also be displayed.

Nether DNCO Combination →no DNCO Function, frequencies will be entered in the table „actual values“.

Switching DNCO-Table 1 via the clamps of this module → The selection of frequencies from the DNCO 1 table can be realized by the bit coded wiring of inputs from this DSV module.

Switching DNCO-Table 2 via the clamps of this module → The selection of frequencies from the DNCO 2 table can be realized by the bit coded wiring of inputs from this DSV module.

Switching DNCO-Table 1 via the clamps of the module→ The selection of frequencies from the DNCO 1 table can be realized by the bit coded wiring of inputs from a defined module. Selecting over DNCO- „Alternative DNCO1-clamps“.

Switching DNCO-Table 2 via the clamps of the

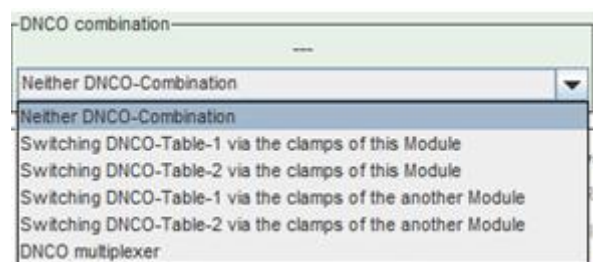

module → The selection of frequencies from the DNCO 2 table can be realized by the bit coded wiring of inputs from a defined module. Selecting over DNCO- „Alternative DNCO1-clamps“.

DNCO multiplexer → The selection of frequencies from the DNCO 1/2 table can be realized by the element Multiplexer. See chapter [DNCO Function with Multiplexer](#)

Once a DNCO combination was selected, this appears in the fields "Actual values". Accept the setting with the "OK" button. The DNCO combination is shown in the logic symbol.

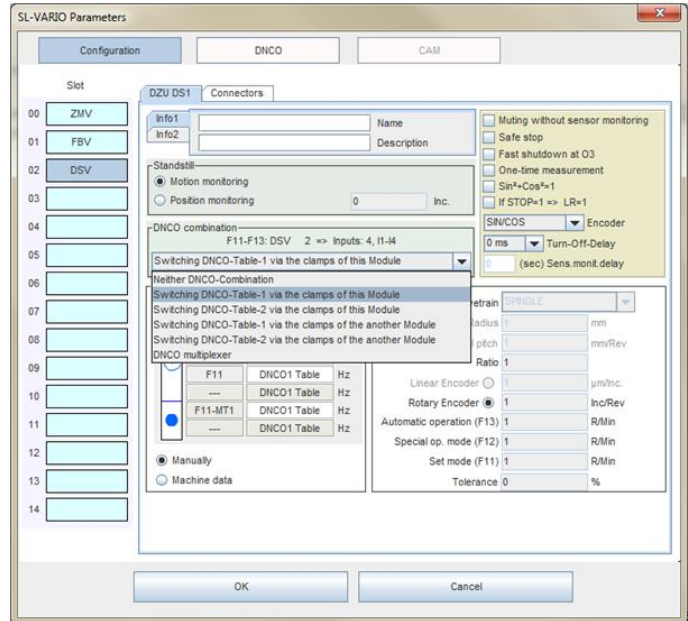

Actual values

Terminals	Frequency	Hz
MT1	no limit	Hz
F13	DNCO1 Table	Hz
F12	DNCO1 Table	Hz
F11	DNCO1 Table	Hz
---	DNCO1 Table	Hz
F11-MT1	DNCO1 Table	Hz
---	DNCO1 Table	Hz

Manually
 Machine data

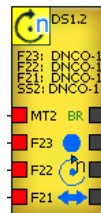

24.3. Frequency tables DNCO 1 und DNCO 2

The DNCO-tables will be selected in the menu Parameter-DNCO. There the frequencies can be entered. It must also be selected if the frequency change is to take place on 4 or 6 inputs. This selection applies to both tables. Mixed operation is not possible!

24.3.1. DNCO-Frequency selection about 4 inputs

Must the selection of the frequencies to be done with 4 inputs, so must first be selected „4 inputs“ in the parameter mask. Then a column with 16 fields is available for each function mode. If desired, only a selection of frequencies in one mode, the other columns may be described by the same values. Thus, it will always be monitored at the same speed even with different wiring of the inputs.

In the fields of the table DNCO 1 or DNCO 2 the monitored frequency values must be entered. By selecting "4 inputs" up to 16 frequencies are available for all function modes.

Tolerance

A tolerance (0-20%) for the monitored speeds can be inserted in the field "Tolerance".

For the function safety is advisable to enter a tolerance of 10%. The tolerance avoids a shutdown by a low, process-related overshoot.

After entering the tolerance value and pressing the button "tolerance", the newly calculated values are entered in the appropriate DNCO table.

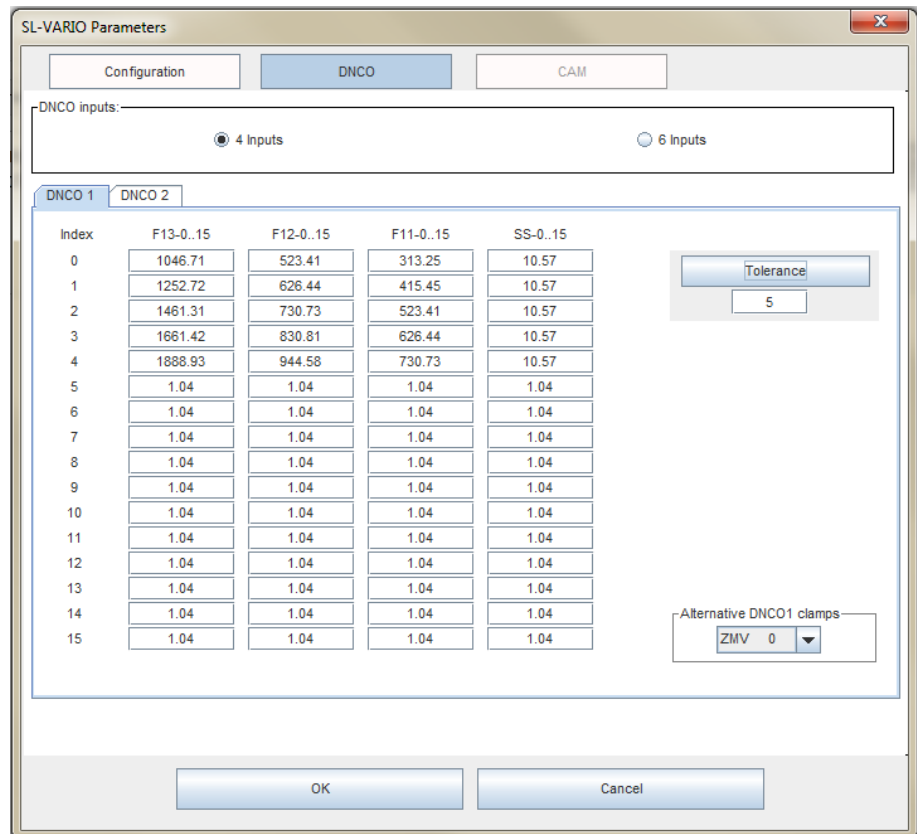

Alternative DNCO1/DNCO2-clamps:

Here, an alternative source of DNCO function can be determined. The terminals of this globally defined module can Instruction manual be selected as an alternative to their own terminals of the DS-Module.

Click on the arrow . Only the positions of the modules in the rack will appear. With their inputs the selection of frequencies in the DNCO table is possible.

The setting will be taken with „OK“.

24.3.2. DNCO-Frequency selection about 6 inputs

Must the selection of the frequencies to be done with 6 inputs, so must first be selected „6 inputs“ in the parameter mask. Then 4 columns with 16 fields are available for the automatic mode. 64 different speeds can be selected.

By selecting "6 inputs" up to 64 frequencies are in each table available for the automatic mode.

Alternative DNCO1/DNCO2-clamps:

Here, an alternative source of DNCO function can be determined. The terminals of this globally defined module can In-struction manual be selected as an alternative to their own terminals of the DS-Module. Click on the arrow. Only the positions of the modules in the rack will appear. With their inputs the selection of frequencies in the DNCO tables is possible.

The setting will be taken with „OK“.

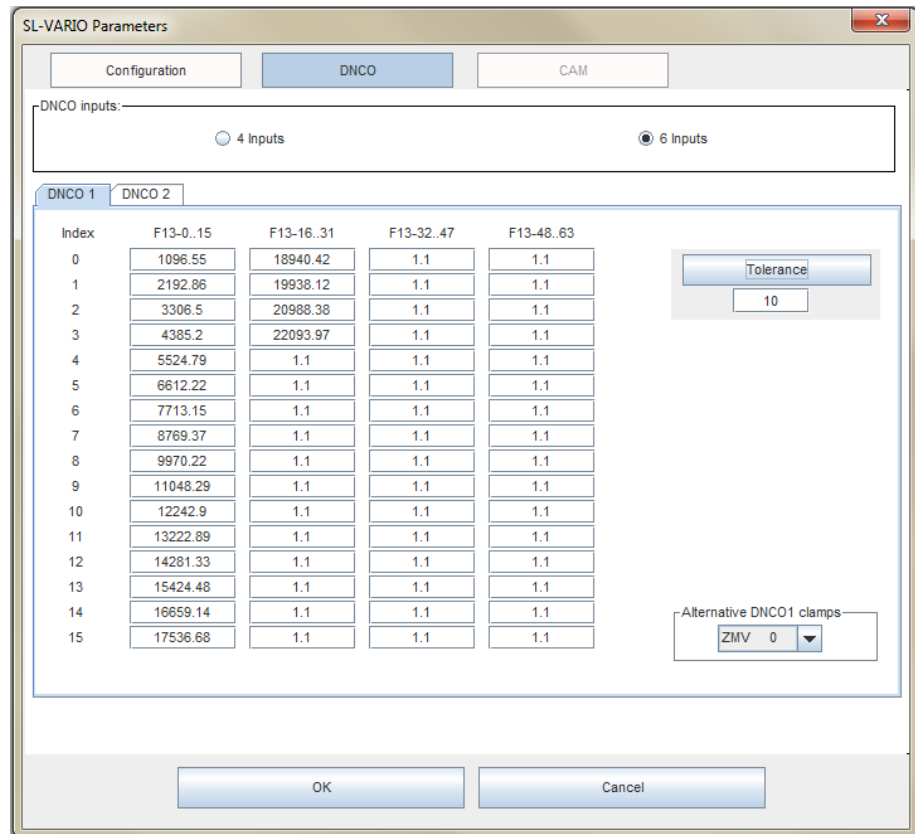

24.4. Example for DNC0 Function

Depending on the wiring of the inputs I5 to I8, the encoder 2 of the DSV should be monitored in various speeds in all modes.

The frequencies are in the DNC0 1 table.

At standstill it should always be monitored to 100 Hz.

1st Step

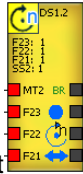

Place the element in the logic circuit.

2nd Step

Select the Parameter menu of the DSV, choose DZU DS2.

DNCO Combination: choose „Switching DNC0-Table 1 via the clamps of this module“. The selection is added to "Actual Values"

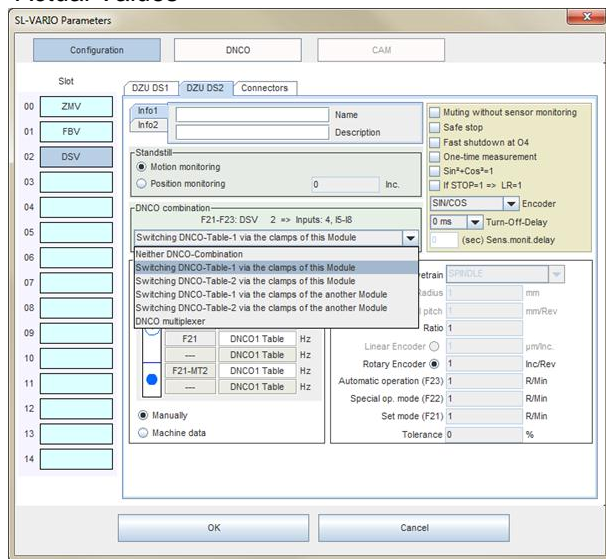

3rd Step

Select DNC0 1.

Enter the frequencies to be monitored and save with OK.

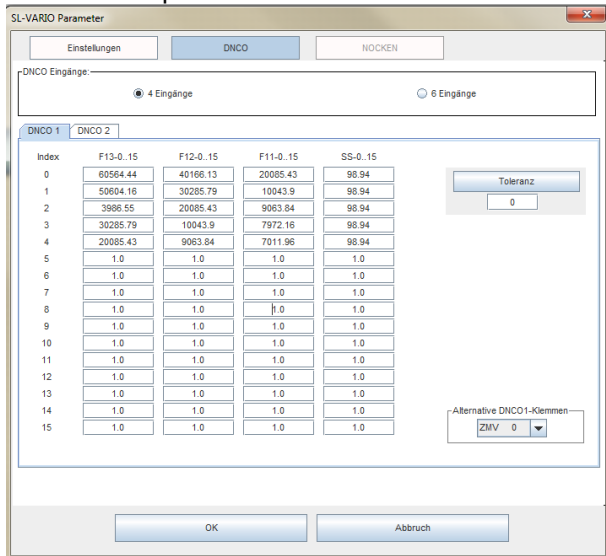

4th Step after transmission the application

Wire the inputs of the DSV. Depending on the wiring of the inputs I5 to I8, the encoder 2 of the DSV will be monitored in the corresponding frequencies of the DNCO table.

Eingänge des DSV				
Index	I8	I7	I6	I5
0	0	0	0	0
1	0	0	0	1
2	0	0	1	0
3	0	0	1	1
4	0	1	0	0
5	0	1	0	1
6	0	1	1	0
7	0	1	1	1
...				

DNCO 1		DNCO 2			
Index	F13-0..15	F12-0..15	F11-0..15	SS-0..15	
0	60564.44	40166.13	20085.43	98.94	
1	50604.16	30285.79	10043.9	98.94	
2	3986.55	20085.43	9063.84	98.94	
3	30285.79	10043.9	7972.16	98.94	
4	20085.43	9063.84	7011.96	98.94	

24.5. DNCO Function with Multiplexer

Is it necessary, to choose the frequencies over any number of inputs, the module "DNCO multiplexer" must be placed in the logic circuit.

Toolbar	Selection	Logic circuit symbol	DNCO 1 Table	Example
	<p>DNCO1 for DZÜ1 DNCO2 for DZÜ2</p>			<p>The inputs IN5 and IN6 are connected with the inputs 2 and 1 of the DNCO Multiplexer. The numbers 1...15 correspond to the Index of the DNCO1 table, in which the frequencies are entered.</p> <p>If input 6 is wired, reference is made to the index 1 in the table DNCO1.</p> <p>The drive is thus monitored on the frequency, which is stored in the index 1.</p> <p>If no input on the multiplexer is connected, so the speed is monitored on the value of index 0.</p>

The assignment of the multiplexer 1 and 2 is fixed!
 The multiplexer 1 (DNCO 1) is used for monitoring the encoder 1.
 The multiplexer 2 (DNCO 2) is used for monitoring the encoder 2.

25. Fieldbus DNSL-FBV/DPV

The field bus includes 4 x 8 inputs (FBI1.1-FBI1.8 to FBI4.1-FBI4.8) and 16 x 8 outputs (FBO1.1-FBO1.8 to FBO16.1- FBO16.8). These can be used for not safety relevant functions
 The inputs are for transmitting signals from Fieldbus Master to SLVario.
 The outputs are for transmitting signals from SLVario to Fieldbus Master.

In addition, 8 safe digital inputs are available.

25.1. Configuration of the fieldbus inputs and outputs

A list of not used inputs appears after a mouse click on the arrow in the toolbar beside the symbol for inputs **In** and for outputs **Out**. After the selection a parameters field will be opened.
 The configuration of fieldbus inputs / outputs does not differ from that of the digital inputs and outputs.

Fieldbus inputs cannot be used for safety relevant functions.



The direct wiring of an FB input to a FB output is only possible if a logic element (AND, OR, ...) is placed in between.

Toolbar	Parameter field	Logic circuit symbol	description
			<p>Fieldbus input Receives data from Fieldbus Master.</p>
			<p>Fieldbus output Sends data to Fieldbus Master.</p>

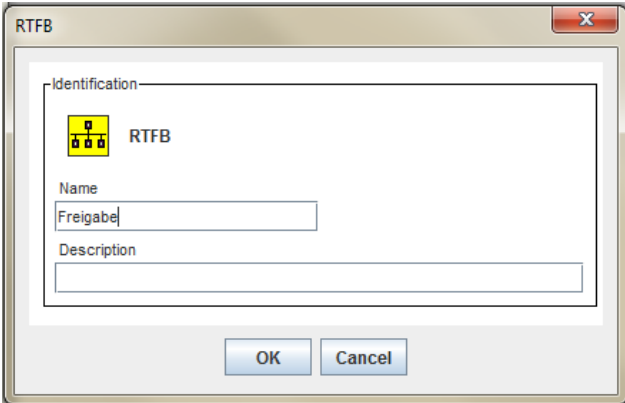
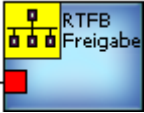
25.2. RTFB

Toolbar	Parameter field	Logic circuit symbol	description
			<p>The RTFB input activates or deactivates the Fieldbus outputs. The symbol is not absolutely necessary, but must be wired, if used. It can only be placed once.</p>

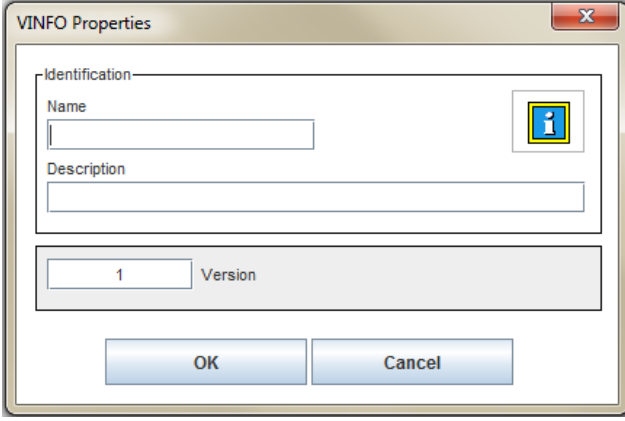
25.3. FB-Version-Information

Toolbar	Parameter field	Logic circuit symbol	description
			<p>VINFO: Compares the entered version with the version information of the fieldbus. (FBO8.1. to FBO8.8). If it is equal, the output gets high.</p>

26. Muting

This option is used for muting function modules, so you can use one application for different variations of machines. If a function module is not used, it can be muted with the parameter of the main module. For muting the inputs I9 to I12 or I13 to I16 (ZMV) are available. Also a module can be muted about the software.

A list of existing modules appears after a mouse click on the arrow. Now you can select which module to be hidden.

Some signals from muted modules can be used nevertheless. The selection of these signals can be made about the button „Selection“.

In the example on the right, the input IN13 of the main module would mute the function module DSV3.



The muted modules must be removed from the rack.

Changing the hardware and transfer the settings only with POWER OFF.

The states of the logic blocks of the muted modules are set at logic "0".

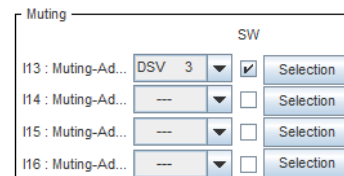
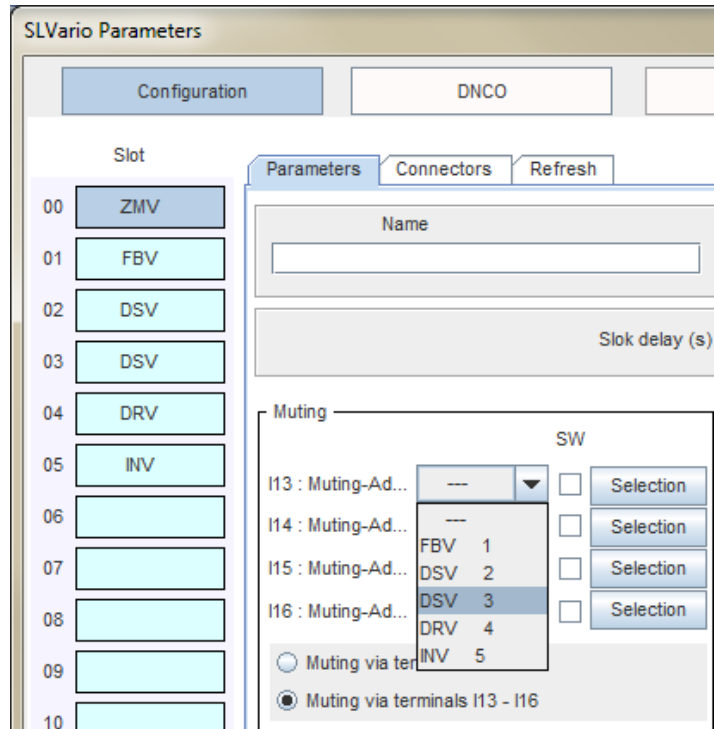

A module can be hidden using the software of the central module. After selecting a module, the hook for the SW Muting can be set.

Should the states of the hidden modules be set to "1", this can be defined by checking the appropriate signals.

In the example, the input IN1 and the output of the SK1 will be set to "1".

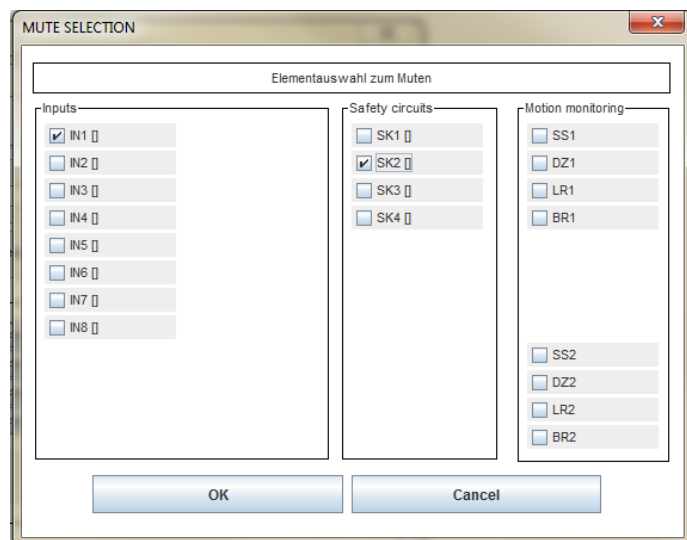

27. Password protection for the application

It is possible to protect the application with passwords. Three configurable levels can be defined. For each level the different responsibilities can be enabled or disabled.

You can define whether the application can be opened in principle or only with entering the correct password, defined by the design engineer.

To open the password settings, follow: Project Password protection.

The parameter field appears.

If the password protection is activated for the application, a padlock and the active level appears in the navigation

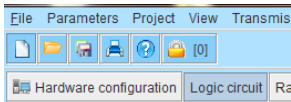

27.1. Options

The settings can be changed only by the engineer in level 0.

Current level:

The current active level in the project.

Activate password protection:

Enable the password protection.

Load application without password request:

Yes: Allows the user to load the application in the defined start-level below.

No: A password request form appears, if someone is loading the saved application.

Define the passwords for the different levels in the 6 fields below.

The passwords consist basically of 6 characters. Special characters aren't allowed.

Accept

The settings are accepted.

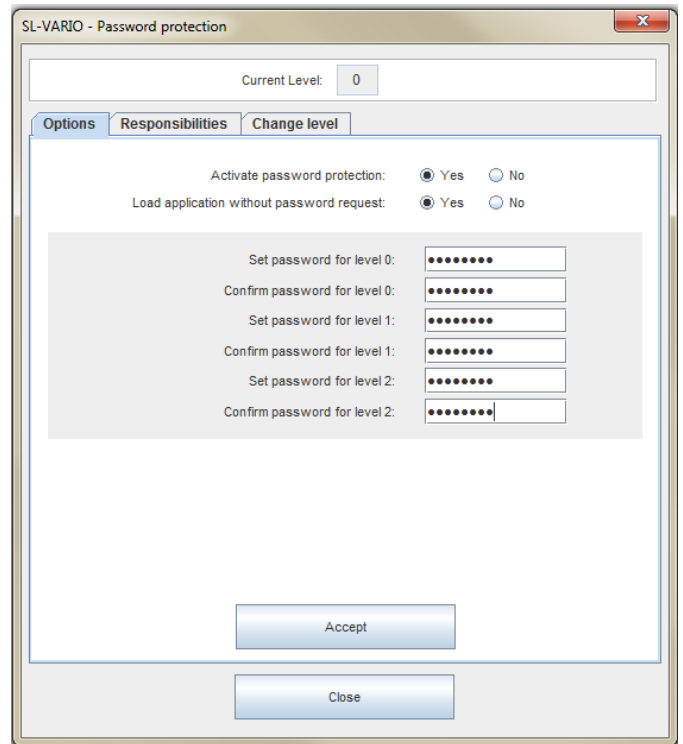

27.2. Responsibilities

The settings can be changed only by the engineer in level 0.

The different responsibilities for level 1 (assembler) and for level 2 (operator) can be defined. The responsibilities for level 0 (engineer) are all enabled.

Current level:

The current active level in the project.

Accept

The settings are accepted.

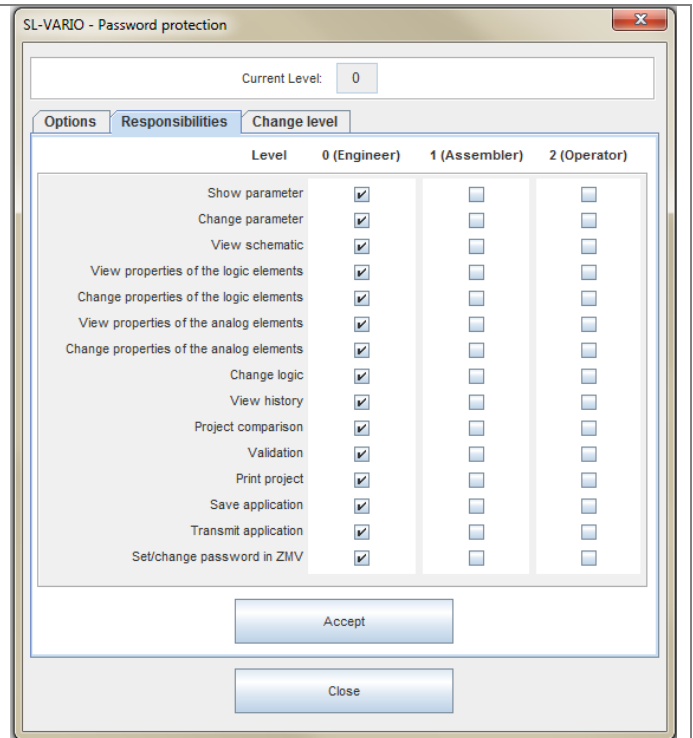

The settings allow the operator the following functions:

Show parameter:

- Viewing the tables

Change parameters:

- Viewing and modifying tables

View schematic:

- View the schematic (logic)

View properties of the logic elements:

- View the properties of the logic blocks in the diagram (logic)

Change properties of the logic elements:

- View and modify the properties of the logic blocks in the diagram (logic)

View properties of the analog elements:

- View the properties of the analog elements in the diagram (logic)

Change properties of the analog elements::

- View and modify the properties of the analog elements in the diagram (logic)

Change logic:

- View the properties of the logic elements in the circuit (logic)
- Add and remove modules in the device configuration
- Adding and Removing logic elements in the circuit (logic)
- Links Add / Delete

View history:

- View the history in the rack diagnosis.

Project comparison

- Execute the menu item [Project comparison](#)

Validation:

- Execute the menu item [Project validation](#)

Print project**Save application****Transmit application****Set/change password in ZMV**

The following actions, are only allowed in level 0, and could not be enabled for level 1/2:

- - Add a page

- - Add label
- - Page arrangement

The settings and responsibilities are accepted by saving the application.

After transmission into the main module, the password from level 0 is saved on the module. Now SLVario is protected! The transmission of another application is only possible with the right password.

If you doesn't need the application protect, but you like to protect the main module, you can do this in the menu [Options](#)



Note: You can save only one password in the main module! In the designer, this password can be generated in two different menus.

Enter password in menu...		DNSL-ZMV device password
1. Project-options-safety options enter PW (8 char.) <input type="text" value="x x x x x x x x"/>	-----> Transmit application	<input type="text" value="x x x x x x x x"/>
2. Project-Password protection enter PW (8 char.) <input type="text" value="x x x x x x x x"/>		



Deleting the access password can be done only in the menu Project-options-safety options.

27.3. Change level

<p><i>Current level:</i> The current active level in the project.</p> <p>The available levels to which the user can change. His states are selectable.</p> <p>Enter the correct password and click on the "Change level"-button. It completes the operation, if the password is correct.</p>	
--	--

27.4. Load an application which is password protected

If the "password protection for application" is active and "loading an application" is also protected, so you have to enter the right password by loading the application.



DINA Elektronik GmbH
Esslinger Straße 84
D-72649 Wolfschlugen
Germany

Phone +49 7022 9517-0
Fax +49 7022 9517-51
info@dinaelektronik.de
www.dinaelektronik.de